



Owner's Manual and Instructions

GUARDIAN • Agricultural Animal Confinement Building Heaters

View this manual online at www.lbwhite.com



MODELS	OUTPUT (Btuh)	FUEL
AD250	250,000	All Models are available in either L.P. Gas Vapor Withdrawal or Natural Gas Configurations.

Certification by:



SCAN THIS QR CODE

with your smartphone or visit <http://goo.gl/nksqZ> to view maintenance videos for L.B.White heaters.*



*Requires an app like QR Droid for Android or QR Reader for iPhone.

Congratulations!

You have purchased the finest agricultural building heater available.

Your new L.B. White heater incorporates the benefits from the most experienced manufacturer of heating products using state-of-the-art technology.

We, at L.B. White, **thank you** for your confidence in our products and welcome any suggestions or comments you may have...call us, toll-free, at 1-800-345-7200.

ATTENTION ALL USERS

This heater has been tested and evaluated by C.S.A. International in accordance with ANSI/IAS U.S. LC2-1998 as well as the Canadian Gas Association Standard for Gas Fired Brooders, CAN1-2.20-M85 and is listed and approved as a direct gas-fired circulating heater for the heating of agricultural animal confinement buildings. If you are considering using this product for any application other than its intended use, then please contact your fuel gas supplier, or the L.B. White Co., Inc.



World Provider - Innovative Heating Solutions

411 Mason Street, Onalaska, WI 54650 ■ (800) 345 7200 ■ (608) 783 5691 ■ (608) 783 6115, fax ■ www.lbwhite.com

150-24207

 **GENERAL HAZARD WARNING**

- Failure to comply with the precautions and instructions provided with this heater, can result in:
 - Death
 - Serious bodily injury or burns
 - Property damage or loss from fire or explosion
 - Asphyxiation due to lack of adequate air supply or carbon monoxide poisoning
 - Electrical shock
- Read this Owner's Manual before installing or using this heater.
- Only properly-trained service people should repair or install this heater.
- Save this Owner's Manual for future use and reference.
- Owner's Manuals and replacement labels are available at no charge. For assistance, contact L.B. White at 800-345-7200.

 **WARNING**

- Proper gas supply pressure must be provided to the inlet of the heater.
- Refer to dataplate for proper gas supply pressure.
- Gas pressure in excess of the maximum inlet pressure specified at the heater inlet can cause fires or explosions.
- Fires or explosions can lead to serious injury, death, building damage or loss of livestock.
- Gas pressure below the minimum inlet pressure specified at the heater inlet may cause improper combustion.
- Improper combustion can lead to asphyxiation or carbon monoxide poisoning and therefore serious injury or death to humans.

 **WARNING**

Fire and Explosion Hazard

- Not for home or recreational vehicle use.
- Installation of this heater in a home or recreational vehicle may result in a fire or explosion.
- Fire or explosions can cause property damage or loss of life.

CONSIGNES DE SECURITE

Il est interdit d'utiliser des liquides inflammables ou dégageant des vapeurs inflammables, a proximite de tout appareil fonctionnant au gaz.

CONSIGNES DE SECURITE

Si vous sentez une odeur de gaz:

1. Ouvrez les fenetres.
2. Ne touchez pas aux interrupteurs electriques.
3. Eteignez toute flamme nue.
4. Contactez immediatement votre compagnie de gaz.

 **WARNING**

Fire and Explosion Hazard

- Keep solid combustibles a safe distance away from the heater.
- Solid combustibles include wood or paper products, feathers, straw, and dust.
- Do not use the heater in spaces which contain or may contain volatile or airborne combustibles.
- Volatile or airborne combustibles include gasoline, solvents, paint thinner, dust particles or unknown chemicals.
- Failure to follow these instructions may result in a fire or explosion.
- Fire or explosions can lead to property damage, personal injury or loss of life.

FOR YOUR SAFETY

Do not store or use gasoline or other flammable vapors and liquids in the vicinity of this or any other appliance.

FOR YOUR SAFETY

If you smell gas:

1. Open windows.
2. Don't touch electrical switches.
3. Extinguish any open flame.
4. Immediately call your gas supplier.



Table of Contents

SECTION	PAGE
General Information	3
Heater Specifications	4
Safety Precautions	5
Installation Instructions	
General	7
Consignes d'installation	
Généralités	9
Air Diverter Installation Instructions	11
Déflecteur d'air Consignes d'Installation	11
Hanging Installation Instructions	12
Consignes de Suspension	12
Sediment Trap Assembly Instructions	13
Assemblage de la Trappe à Sédiments	13
Manual Shut-Off Valve, Hose, and Regulator Assembly Instructions	14
Assemblage du Robinet d'Arret Manuel, du Tuyau et du Regulateur	14
Thermostat Installation	15
Installation du Thermostat	15
Start-Up Instructions	16
Shut-Down Instructions	16
Consignes de Démarrage	17
Consignes d'Extinction	17
Variable Heat Output	18
Cleaning Instructions	19
Maintenance Instructions	19
Service Instructions	
General	20
Motor & Fan Assembly	20
Air Proving Switch with Paddle	21
Igniter/Flame Sensor Assembly	21
High Limit Switch	22
Transformer	22
Burner Orifice and Gas Control Valve	23
Ignition Control	23
Gas Pressure Checks	24
Troubleshooting Instructions	25
Electrical Connection and Ladder Diagram	30
Heater Component Function	31
Parts Identification (Parts List & Schematic)	32 & 33
Warranty Policy,Replacement Parts and Service	34

General Information

This Owner's Manual includes all options and accessories commonly used on this heater. However, depending on the configuration purchased, some options and accessories may not be included.

When calling for technical service assistance, or for other specific information, always have model number, configuration number and serial number available. This information is contained on the dataplate.

This manual will instruct you in the operation and care of your unit. Have your installer review this manual with you so that you fully understand the heater and how it functions.

Contact your local L.B. White distributor or the L.B. White Co., Inc. for assistance, or if you have any questions about the use of the equipment or its application.

The L.B. White Co., Inc. has a policy of continuous product improvement. It reserves the right to change specifications and design without notice.

Heater Specifications

Model

AD250

SPECIFICATIONS

		L.P Gas	Natural Gas
Maximum Input (BTUH)		250,000	
Minimum Input (BTUH)		160,000	
Ventilation Air Required to Support Combustion		1,050 CFM	
Inlet Gas Supply Pressure Acceptable at the Inlet of the Heater for Purpose of Input Adjustment	MAX.	13.5 in. W.C.	
	MIN.	11 in. W.C.	7 in. W.C.
Burner Manifold Pressure		10 in. W.C.	4 in. W.C.
Fuel Consumption Per Hour	MAX.	11.58 lbs.	250 cu. ft.
	MIN.	7.41 lbs.	160 cu. ft.
Motor Characteristics		Ball Bearing 1/3 H.P. 1100 RPM	
Electrical Supply (Volts/Hz/Phase)		115/60/1	
Amp Draw	STARTING	7.3	
	CONTINUOUS OPERATION	4.5	
Dimensions (Inches) L x W x H		30 3/4 x 18 1/4 x 28 1/4	
Minimum Safe Distances From Nearest Combustible Materials	TOP	1 ft. (.3 m)	
	SIDES	1 ft. (.3 m)	
	BACK	1 ft. (.3 m)	
	BLOWER OUTLET	6 ft. (1.83 m)	
	GAS SUPPLY	L.P. Gas Supply – 6 ft. (1.83 m) Natural Gas Supply – N/A	

Safety Precautions

WARNING **Asphyxiation Hazard**

- Do not use this heater for heating human living quarters.
- Do not use in unventilated areas.
- The flow of combustion and ventilation air must not be obstructed.
- Proper ventilation air must be provided to support the combustion air requirements of the heater being used.
- Refer to the specification section of the heater's Owner's Manual, heater dataplate, or contact the L.B. White Company to determine combustion air ventilation requirements of the heater.
- Lack of proper ventilation air will lead to improper combustion.
- Improper combustion can lead to carbon monoxide poisoning leading to serious injury or death. Symptoms of carbon monoxide poisoning can include headaches, dizziness and difficulty in breathing.
- Symptoms of improper combustion affecting livestock can be disease, lower feed conversion, or death.

Propane gas and natural gas have man-made odorants added specifically for detection of fuel gas leaks. If a gas leak occurs, you should be able to smell the fuel gas. THAT'S YOUR SIGNAL TO GO INTO IMMEDIATE ACTION!

- Do not take any action that could ignite the fuel gas. Do not operate any electrical switches. Do not pull any power supply or extension cords. Do not light matches or any other source of flame. Do not use your telephone.
- Get everyone out of the building and away from the area immediately.
- Close all propane gas tank or cylinder fuel supply valves, or the main fuel supply valve located at the meter if you use natural gas.
- Propane gas is heavier than air and may settle in low areas. When you have reason to suspect a propane leak, keep out of all low areas.
- Use your neighbor's phone and call your fuel gas supplier and your fire department. Do not re-enter the building or area.
- Stay out of the building and away from the area until declared safe by the firefighters and your fuel gas supplier.
- **FINALLY**, let the fuel gas service person and the firefighters check for escaped gas. Have them air out the building and area before you return. Properly trained service people must repair the leak, check for further leakages, and then relight the appliance for you.

ODOR FADING -- NO ODOR DETECTED

- **Some people cannot smell well. Some people cannot smell the odor of the man-made chemical added to propane or natural gas. You must determine if you can smell the odorant in these fuel gases.**
- Learn to recognize the odor of propane gas and natural gas. Local propane gas dealers will be more than happy to give you a scratch and sniff pamphlet. Use it to become familiar with the fuel gas odor.
- Smoking can decrease your ability to smell. Being around an odor for a period of time can affect your sensitivity to that particular odor.
- The odorant in propane gas and natural gas is colorless and the intensity of its odor can fade under some circumstances.
- If there is an underground leak, the movement of gas through the soil can filter the odorant.
- Propane gas odor may differ in intensity at different levels. Since propane gas is heavier than air, there may be more odor at lower levels.
- **Always be sensitive to the slightest gas odor.** If you continue to detect any gas odor, no matter how small, treat it as a serious leak. Immediately go into action as discussed previously.

ATTENTION -- CRITICAL POINTS TO REMEMBER!

- Propane gas has a distinctive odor. Learn to recognize these odors. (Reference Fuel Gas Odor and Odor Fading sections above.)
- If you have not been properly trained in repair and service of propane gas then do not attempt to light heater, perform service or repairs, or make any adjustments to the heater on the propane gas fuel system.
- Even if you are not properly trained in the service and repair of the heater, ALWAYS be consciously aware of the odors of propane gas and natural gas.
- A periodic sniff test around the heater or at the heater's joints; i.e. hose, connections, etc., is a good safety practice under any conditions. If you smell even a small amount of gas, CONTACT YOUR FUEL GAS SUPPLIER IMMEDIATELY. DO NOT WAIT!

1. Do not attempt to install, repair, or service this heater or the gas supply line unless you have continuing expert training and knowledge of gas heaters.

Qualifications for service and installation of this equipment are as follows:

- a. To be a qualified gas heater service person, you must have sufficient training and experience to handle all aspects of gas-fired heater installation, service and repair. This includes the task of installation, troubleshooting, replacement of defective parts and testing of the heater. You must be able to place the heater into a continuing safe and normal operating condition. You must completely familiarize yourself with each model heater by reading and complying with the safety instructions, labels, Owner's Manual, etc., that is provided with each heater.
 - b. To be a qualified gas installation person, you must have sufficient training and experience to handle all aspects of installing, repairing and altering gas lines, including selecting and installing the proper equipment, and selecting proper pipe and tank size to be used. This must be done in accordance with all local, state and national codes as well as the manufacturer's requirements.
2. All installations and applications of L.B. White heaters must meet all relevant local, state and national codes. Included are L.P. gas, natural gas, electrical, and safety codes. Your local fuel gas supplier, a local licensed electrician, the local fire department or similar government agencies, or your insurance agent can help you determine code requirements.
 - a. For U.S.A. installations and applications:
 - ANSI/NFPA 58, latest edition, Standard for Storage and Handling of Liquefied Petroleum Gas and/or
 - ANSI Z223.1/NFPA 54, National Fuel Gas Code
 - ANSI/NFPA 70, National Electrical Code.
 - b. For Canadian Installations and Applications:
 - CAN1-B149.1 or CAN1-B149.2 Installation Codes
 - CSA C22.1 Part 1 Standard Canadian Electrical Code. CSA C22.2 No. 3, Electrical Features of Fuel-Burning Equipment.
 3. Do not move, handle, or service heater while in operation or connected to a power or fuel supply.
 4. This heater may be installed in areas subject to washdown. This heater may only be washed on the external case assembly—see Cleaning Instructions. Do not wash the interior of the heater. Use only compressed air, soft brush or dry cloth to clean the interior of the heater and its components. After external washdown, do not operate this heater until it is completely dry. In any event, do not operate the heater for at least one hour after external washdown.

5. For safety, this heater is equipped with a manual reset high-limit switch and an air proving switch. Never operate this heater with any safety device that has been bypassed. Do not operate this heater unless all of these features are fully functioning.
6. Do not operate the heater with its door open or panel removed.
7. Do not locate fuel gas containers or fuel supply hoses anywhere near the blower outlet of the heater.
8. Do not block air intakes or discharge outlets of the appliance. Doing so may cause improper combustion or damage to heater components leading to property damage or animal loss.
9. The hose assembly (if provided) shall be visually inspected on an annual basis. If it is evident there is excessive abrasion or wear, or if the hose is cut, it must be replaced prior to the heater being put into operation. The hose assembly shall be protected from animals, building materials, and contact with hot surfaces during use. The hose assembly shall be that specified by the manufacturer. See parts list.
10. Check for gas leaks and proper function upon heater installation, before building repopulation or when relocating.
11. This heater should be inspected for proper operation by a qualified service person before building repopulation and at least annually.
12. Always turn off the gas supply to the appliance if the appliance is not going to be used in the heating of livestock.
13. This heater is equipped with a three-prong (grounding) plug for your protection against shock hazard and must be plugged directly into a properly grounded three-prong receptacle. Failure to use a properly grounded receptacle can result in electrical shock, personal injury, or death.
14. Direct ignition heaters will make up to three trials for ignition. If ignition is not achieved, the control system will lock out the gas control valve. If gas is smelled after system lock out has occurred, immediately close all fuel supply valves. Do not relight until you are sure that all gas that may have accumulated has cleared away. In any event, do not relight for at least 5 minutes.
15. In a hanging type installation, rigid pipe or copper tubing coupled directly to the heater may cause gas leaks during movement, and therefore must not be used. Use only gas hose assemblies that are rated and approved for L.P.gas and natural gas in a hanging type of installation.
16. Installations not using the gas hose supplied with this appliance must connect dimensionally using American National Standard Wrought Steel and Wrought Iron Pipe B36/10-1970. (Aluminum piping or tubing shall not be used.) Copper tubing when used for conveying natural gas, shall be internally tinned or equivalently treated to resist sulphur.

Installation Instructions

GENERAL



WARNING

Fire or explosion hazard.

Can cause property damage, severe injury or death.

1. Disconnect power supply before wiring to prevent electrical shock or equipment damage.
 2. To avoid dangerous accumulation of fuel gas, turn off gas supply at the appliance service valve before starting installation, and perform gas leak test after completion of installation.
 3. Do not force the gas control knob. Use only your hand to turn the gas control knob. Never use any tools. If the knob will not operate by hand, the control should be replaced by a qualified service technician. Force or attempted repair may result in fire or explosion.
1. Read all safety precautions and follow L. B. White recommendations when installing this heater. If during the installation or relocating of heater, you suspect that a part is damaged or defective, call a qualified service agency for repair or replacement.
 2. Make sure the heater is properly positioned before use and is hung level. Observe and obey all minimum safe distances of the heater to the nearest combustible materials. Minimum safe distances are given on the heater nameplate and on page 4 of this manual.
 3. For heaters intended for outdoor installation, the heater is to be installed at least 18 inches above the ground or to a height that would prevent snow blockage of heater's air inlet.
 4. The heater may be used either indoors or outdoors. When the heater is mounted outdoors, use only the ductwork supplied in the outdoor mounting kit.
 5. The heater must have the proper gas regulator installed for the application. A regulator must be connected to the gas supply so that gas pressure at the inlet to the gas valve is regulated within the range specified on the dataplate at all times. Contact your gas supplier, or the L.B. White Co., Inc. if you have any questions.
 6. The heater's gas regulator (with pressure relief valve) should be installed outside of building. Any regulators inside the buildings must be properly vented to the outside. Local, state and national codes always apply to regulator installation. Natural gas regulators with vent limiting device may be mounted indoors without venting to outdoors.
 7. All gas pressure regulators must be installed in strict accordance with the manufacturer's safety instructions. These instructions accompany each regulator.
 8. Insure that all accessories that ship within the heater have been removed from inside of heater and installed. This pertains to air diverters, hose, regulators, etc.

9. Make certain that a sediment trap is installed at the gas valve inlet to prevent foreign materials (pipe compound, pipe chips and scale) from entering the gas valve. Debris blown into the gas valve may cause that valve to malfunction resulting in a serious gas leak that could result in a possible fire or explosion causing loss of products, building or even life. A properly installed sediment trap will keep foreign materials from entering the gas valve and protect the safe functioning of that important safety component.
10. Any heater connected to a piping system must have an accessible, approved manual shut off valve installed within six feet (6 ft.) of the heater it serves.
11. Check all connections for gas leaks using approved gas leak detectors. Gas leak testing is performed as follows:



WARNING

Fire and Explosion Hazard

- Do not use open flame (matches, torches, candles, etc.) in checking for gas leaks.
 - Use only approved leak detectors.
 - Failure to follow this warning can lead to fires or explosions.
 - Fires or explosions can lead to property damage, personal injury or loss of life.
- Check all pipe connections, hose connections, fittings and adapters upstream of the gas control with approved gas leak detectors.
 - In the event a gas leak is detected, check the components involved for cleanliness and proper application of pipe compound before further tightening.
 - Furthermore tighten the gas connections as necessary to stop the leak.
 - After all connections are checked and any leaks are stopped, turn on the main burner.
 - Stand clear while the main burner ignites to prevent injury caused from hidden leaks that could cause flashback.
 - With the main burner in operation, check all connections, hose connections, fittings and joints as well as the gas control valve inlet and outlet connections with approved gas leak detectors.
 - If a leak is detected, check the components involved for cleanliness in the thread areas and proper application of pipe compound before further tightening.
 - Tighten the gas connection as necessary to stop the leak.
 - If necessary, replace the parts or components involved if the leak cannot be stopped.
 - Ensure all gas leaks have been identified and repaired before proceeding.

12. A qualified service agency must check for proper operating gas pressure upon installation of the heater.
13. Light according to instructions on heater or within owner's manual.
14. It is extremely important to use the proper size and type of gas supply line to assure proper functioning of the heater. Contact your fuel gas supplier for proper line sizing and installation.
15. This heater can be configured for use with either L.P. gas vapor withdrawal or natural gas. Consult the dataplate, located on interior of the burner end or motor end door, for the gas configuration of the specific heater. Do not use the heater in an L.P. gas liquid withdrawal system or application. If you are in doubt, contact the L.B. White Co., Inc.
16. Eventually, like all electrical/mechanical devices, the thermostat can fail. Thermostat failure may result in either an underheating or overheating condition which may damage critical products and/or cause animal injury or death. Critical products and/or animals should be protected by a separate back-up control system that limits high and low temperatures and also activates appropriate alarms.
17. Take time to understand how to operate and maintain the heater by using this Owner's Manual. Make sure you know how to shut off the gas supply to the building and also to the individual heater. Contact your fuel gas supplier if you have any questions.
18. Any defects found in performing any of the service or maintenance procedures must be eliminated and defective parts replaced immediately. The heater must be retested by properly qualified service personnel before placing the heater back into use.
19. Do not exceed input rating stamped on the dataplate of the heater. Do not exceed the burner manifold pressure stated on the dataplate. Do not use an orifice size different than specified for the specific input rating of this heater, fuel type configuration and altitude.



MISE EN GARDE

Risque d'incendie ou d'explosion.

Peut entraîner des dommages matériels, des blessures graves, voire la mort.

1. Débranchez l'alimentation électrique avant de procéder au câblage afin de prévenir les électrocutions ou les dommages à l'équipement.
2. Pour éviter l'accumulation de gaz combustibles dangereux, fermez l'alimentation en gaz au clapet d'alimentation de l'appareil avant de commencer l'installation, et effectuez une vérification des fuites de gaz une fois l'installation terminée.
3. Ne forcez pas le bouton de réglage du gaz. Ne tournez le bouton de réglage du gaz qu'à la main. N'utilisez jamais d'outil. Si le bouton ne tourne pas à la main, il doit être remplacé par un technicien en entretien et en réparation qualifié. Le fait de forcer ou de tenter de réparer le bouton peut provoquer un incendie ou une explosion.

1. Lisez toutes les précautions de sécurité et suivez les recommandations de L. B. White lorsque vous installez cet appareil de chauffage. Si, au cours de l'installation ou du déplacement de l'appareil de chauffage, vous soupçonnez qu'une pièce est endommagée ou défectueuse, appelez une entreprise d'entretien et de réparation qualifiée pour qu'elle répare ou la remplace.
2. Assurez-vous que l'appareil de chauffage se trouve dans la bonne position avant de l'utiliser, et qu'il est suspendu de niveau. Respectez toutes les distances minimales sécuritaires entre l'appareil de chauffage et les matériaux combustibles à sa proximité. Les distances sécuritaires minimales figurent sur la plaque signalétique de l'appareil de chauffage et sont indiquées à la page 4 du présent guide.
3. Les appareils de chauffage prévus pour être installés à l'extérieur doivent être positionnés au moins à 18 pouces du sol ou à une hauteur qui prévient le blocage de l'alimentation en air de l'appareil de chauffage par la neige.
4. L'appareil de chauffage peut être utilisé à l'intérieur ou à l'extérieur. Lorsque l'appareil de chauffage est monté à l'extérieur, n'utilisez que le réseau de gaines fourni avec la trousse de montage à l'extérieur.
5. Il faut installer le régulateur de gaz approprié qui convient à l'utilisation de l'appareil de chauffage. Un régulateur doit être branché à l'alimentation en gaz afin que la pression de gaz à l'entrée de la valve à gaz reste toujours dans les limites spécifiées sur la plaque signalétique. Prenez contact avec votre fournisseur de gaz ou avec L.B. White Co. pour toute question éventuelle.

6. Le régulateur de gaz de l'appareil de chauffage (équipé d'une valve de protection contre la surpression) doit être installé à l'extérieur du bâtiment. Tout régulateur se trouvant à l'intérieur d'un bâtiment doit être équipé d'une mise à l'air libre extérieur appropriée. Les codes municipaux, les codes d'État et les codes nationaux s'appliquent toujours à l'installation des régulateurs. Les régulateurs de gaz naturel munis d'un dispositif limiteur de débit peuvent être montés à l'intérieur sans mise à l'air libre extérieur.
7. Tous les régulateurs de pression de gaz doivent être installés et utilisés en suivant les consignes de sécurité du fabricant à la lettre. Ces consignes accompagnent chaque régulateur.
8. Assurez-vous que tous les accessoires expédiés avec l'appareil de chauffage ont été retirés de l'intérieur de l'appareil et installés. Cela concerne les déflecteurs d'air, les tuyaux, les régulateurs, etc.
9. Assurez-vous qu'une trappe à sédiments est installée à l'entrée de la valve de gaz afin d'empêcher les matériaux étrangers (mastic pour joints de tubes, éclats et écailles de tuyau) de pénétrer dans la valve de gaz. Des débris qui volent dans la valve de gaz peuvent causer un mal fonctionnement de cette dernière, ce qui peut entraîner une grave fuite de gaz qui pourrait provoquer un incendie ou une explosion résultant dans la perte de produits, de bâtiments ou même de vies. Une trappe à sédiments correctement installée empêche les matériaux étrangers de pénétrer dans la valve de gaz et assure le bon fonctionnement de cet important dispositif de sécurité.
10. Tout appareil de chauffage branché à une tuyauterie doit être équipé d'un robinet d'arrêt manuel homologué accessible situé à une distance maximale de 6 pieds (6 pi) de l'appareil concerné.
11. Vérifiez tous les raccords à l'aide d'un détecteur de fuites de gaz homologué. La vérification des fuites de gaz est effectuée comme suit:



MISE EN GARDE

Risque d'incendie et d'explosion

- N'utilisez pas de flamme nue (allumette, torche, bougie, etc.) pour vérifier la présence de fuites de gaz.
- N'utilisez que des détecteurs de fuites homologués.
- Le non-respect de cette mise en garde peut provoquer un incendie ou une explosion.
- Les incendies ou les explosions peuvent entraîner des dommages matériels, des blessures ou la mort.

- Vérifiez tous les raccords de canalisation et de tuyauterie et les adaptateurs en amont du régulateur de gaz à l'aide d'un détecteur de fuites de gaz homologué.

- Si une fuite est détectée, vérifiez la propreté et l'application correcte du mastic pour joints de tube des composants concernés avant de les resserrer davantage.
 - En outre, resserrez les raccords de gaz, selon les besoins, afin d'arrêter la fuite.
 - Une fois tous les raccords vérifiés et toutes les fuites arrêtées, allumez le brûleur principal.
 - Tenez-vous à distance de l'appareil pendant l'allumage du brûleur principal afin d'éviter toute blessure éventuelle causée par des fuites cachées qui pourraient provoquer un retour de flamme.
 - Pendant que le brûleur principal fonctionne, vérifiez tous les raccords et les joints de tuyauterie, ainsi que les raccords d'entrée et de sortie de la valve de contrôle du gaz à l'aide d'un détecteur de fuites de gaz homologué.
 - Si une fuite est détectée, vérifiez la propreté des composants concernés et l'application correcte du mastic pour joints de tube dans les zones filetés avant de les resserrer davantage. .
 - Resserrez les raccords de gaz, au besoin, afin d'arrêter la fuite.
 - Si nécessaire, remplacez les pièces ou les composants concernés, s'il est impossible d'arrêter la fuite.
 - Assurez-vous que toutes les fuites de gaz ont été détectées et réparées avant de continuer. all gas leaks have been identified and repaired before proceeding.
12. Une entreprise d'entretien et de réparation qualifiée doit vérifier que la pression de gaz de fonctionnement est correcte après l'installation de l'appareil de chauffage.
 13. Allumez l'appareil conformément aux consignes situées sur ce dernier ou dans le mode d'emploi.
 14. Il est extrêmement important d'utiliser une canalisation d'alimentation en gaz de la bonne taille et du bon type pour assurer le bon fonctionnement de l'appareil de chauffage. Prenez contact avec votre fournisseur de gaz combustible pour obtenir la taille correcte de la canalisation et la façon de l'installer.
 15. Cet appareil de chauffage peut être configuré pour une utilisation par soutirage de vapeur de GPL ou avec du gaz naturel. Consultez la plaque de données, située à l'intérieur de la porte du brûleur ou du moteur, qui indique la configuration de gaz du brûleur en question. N'utilisez pas l'appareil de chauffage pour une utilisation ou dans un système de soutirage de vapeur de GPL. Dans le doute, prenez contact avec L.B. White Co., Inc.
 16. Comme c'est le cas de tous les dispositifs électriques ou mécaniques, le thermostat finira par tomber en panne. Une panne de thermostat peut entraîner soit un chauffage insuffisant, soit une surchauffe qui peut endommager des produits essentiels ou causer des blessures ou la mort d'un animal. Les produits essentiels et les animaux doivent être protégés par un système de contrôle de secours distinct qui limite les températures élevées et faibles et active également les alarmes appropriées.
 17. Prenez le temps nécessaire pour comprendre comment faire fonctionner l'appareil de chauffage et comment l'entretenir à l'aide du présent mode d'emploi. Assurez-vous de savoir comment couper l'alimentation en gaz du bâtiment et de l'appareil de chauffage. Prenez contact avec votre fournisseur de gaz combustibles en cas de question.
 18. Tout défaut constaté lors d'une procédure d'entretien ou de réparation quelconque doit être éliminé, et les pièces défectueuses doivent être immédiatement remplacées. L'appareil de chauffage doit faire l'objet de nouveaux tests effectués par un membre du personnel d'entretien et de réparation qualifié avant que l'appareil ne soit remis en service.
 19. Ne dépassez pas le débit calorifique marqué sur la plaque de données de l'appareil de chauffage. Ne dépassez pas la pression de la canalisation du brûleur indiquée sur la plaque de données. N'utilisez pas une taille d'orifice autre que celle qui est indiquée pour le débit calorifique de cet appareil de chauffage, la configuration du type de combustible et l'altitude.

AIR DIVERTER INSTALLATION INSTRUCTIONS

(Accessory on some models.)

(Appearance of the outlet on heater may vary from model to model.)

1. Air diverters can be installed in the heater outlet to provide direction to the heated air as it exits the heater. Installation options include installing the diverters in such a way as to broadly distribute the air in two 45 degree paths or to focus the air flow in one 45 degree direction. See Fig. 2.
2. The air diverters may require hand forming prior to installation. Make 90 degree bends utilizing the perforations provided. Diverter should then have the shape shown in Fig. 2.
3. The air diverter's tabs on each half will pop into the blower outlet between the inside of the case assembly and the blower housing outlet. If the notched tabs do not pop into the blower outlet, loosen (do not remove) the blower outlet screws. Doing this provides a gap into which you can insert the tabs. Retighten the screws after installation.

FIG. 2 (Typical installation allowing two directions of air movement.)

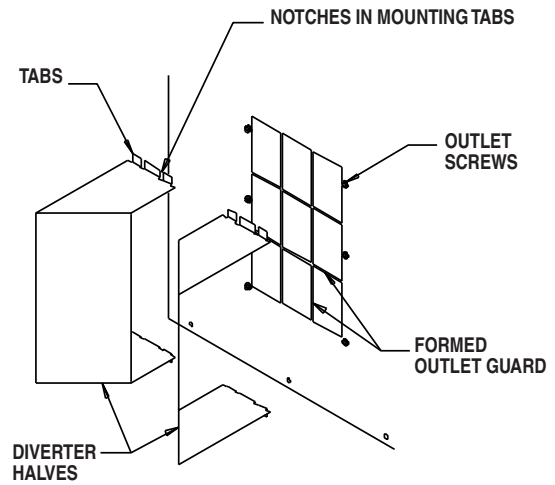

Alternate Air Diverter Installations



DÉFLECTEUR D'AIR CONSIGNES D'INSTALLATION

(Accessoire sur certains modèles.)

(L'aspect de la sortie sur l'appareil de chauffage peut varier d'un modèle à l'autre.)

1. Des déflecteurs d'air optionnels peuvent être installés sur la sortie de l'appareil de chauffage afin de diriger l'air chauffé qui sort de l'appareil. Il est possible notamment d'installer les déflecteurs d'air de sorte à distribuer l'air en gros en deux trajectoires à 45 degrés ou de cibler le débit d'air dans une direction à 45 degrés. Consultez la figure 2.
2. Il se peut que vous deviez donner une forme à la main aux déflecteurs d'air avant de les installer. Formez des plis à 90 degrés à l'aide des perforations fournies. Le déflecteur d'air devrait alors prendre la forme décrite à la figure 2.
3. Les languettes du déflecteur d'air situées sur chaque moitié entrent dans la sortie du ventilateur, entre l'intérieur de l'assemblage du boîtier et la sortie du boîtier du ventilateur. Si les languettes entaillées n'entrent pas dans la sortie du ventilateur, desserrez (sans les retirer) les vis de la sortie du ventilateur. Cela crée un espace dans lequel vous pouvez insérer les languettes. Resserrez les vis après l'installation.

FIG. 2 (installation typique permettant à l'air de se déplacer dans deux directions.)

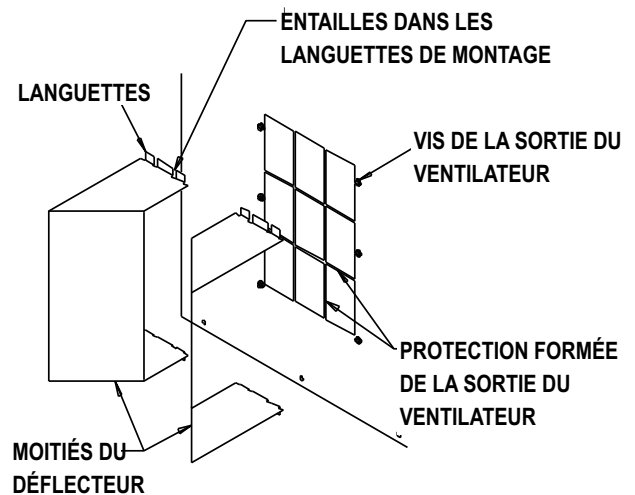

Autre installation possible du déflecteur d'air



HANGING INSTRUCTIONS

1. Assemble according to the illustration and tighten all eyebolts securely. See Fig. 3.

FIG. 4

NOTE: REGULATORS SHOULD ALWAYS BE MOUNTED OUTDOORS. IF CIRCUMSTANCES FORCE INSTALLING THE REGULATOR INDOORS, THE REGULATOR'S VENT MUST BE VENTED OUTDOORS USING VENT LINE NO SMALLER THAN VENT OPENING.

FIG. 3

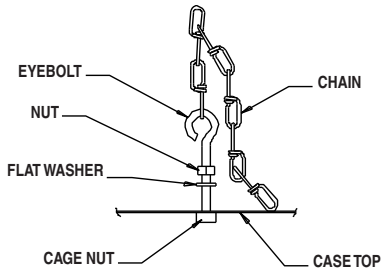

2. Be sure heater is securely fastened and is hanging level. (Check crosswise and lengthwise.)
3. See Fig. 4 for **typical** indoor installation. In any animal confinement building, consideration must be given to making sure the heater is located away from the livestock so that livestock cannot knock the heater, tear it loose from its mounting, or damage the heater or its gas supply line in any way. Make sure you observe and obey minimum clearance distances to combustible materials as stated in the specification section of this owner's manual and on the heater itself.

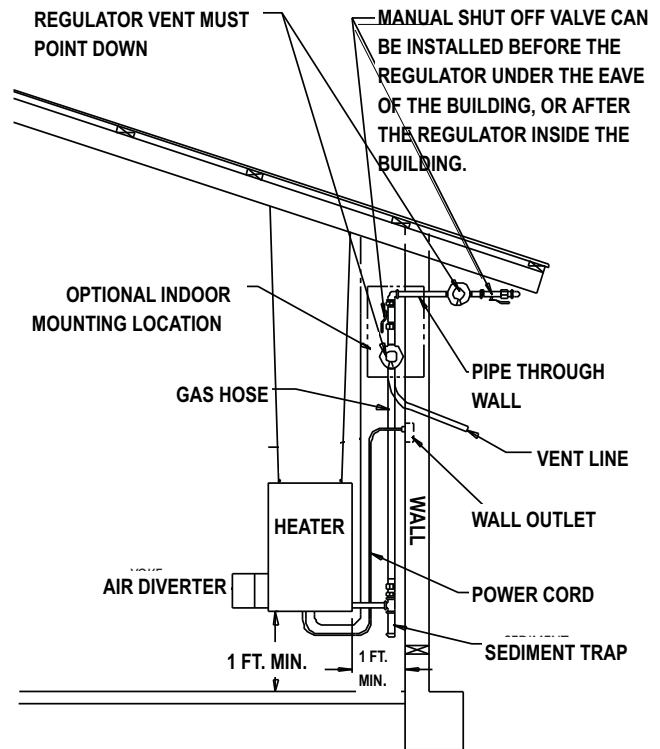

CONSIGNES DE SUSPENSION

1. Assemblez le mécanisme selon l'illustration et resserrez bien tous les boulons à œil. Consultez la figure 3.

FIG. 4

REMARQUE : LES RÉGULATEURS DOIVENT TOUJOURS ÊTRE MONTÉS À L'EXTÉRIEUR. SI LES CIRCONSTANCES OBLIGENT L'INSTALLATEUR À INSTALLER LE RÉGULATEUR À L'INTÉRIEUR, L'ÉVENT DU RÉGULATEUR DOIT ÊTRE ÉQUIPÉ D'UNE MISE À L'AIR LIBRE EXTÉRIEUR À L'AIDE D'UNE CONDUITE DE MISE À L'AIR LIBRE D'UN DIAMÈTRE NON INFÉRIEUR À CELUI DE L'ORIFICE DE L'ÉVENT.

FIG. 3

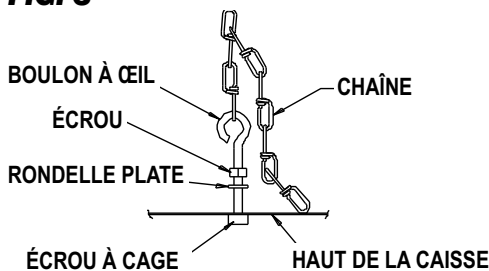

2. Assurez-vous que l'appareil de chauffage est bien fixé et est suspendu de niveau. (Vérifiez le niveau en diagonale et dans le sens de la largeur.)
3. Consultez la figure 4 pour voir une installation typique à l'intérieur. Dans tout bâtiment agricole pour bétail, il faut prendre soin de s'assurer que l'appareil de chauffage est situé à bonne distance du bétail, afin que ce dernier ne puisse pas le renverser, le dégager de son support ou endommager l'appareil ou sa canalisation d'alimentation en gaz de quelque manière que ce soit. Assurez-vous d'observer et de respecter les distances de dégagement minimales par rapport aux matériaux combustibles, telles qu'elles sont indiquées dans la section du présent mode d'emploi consacrée aux spécifications, et sur l'appareil de chauffage lui-même.

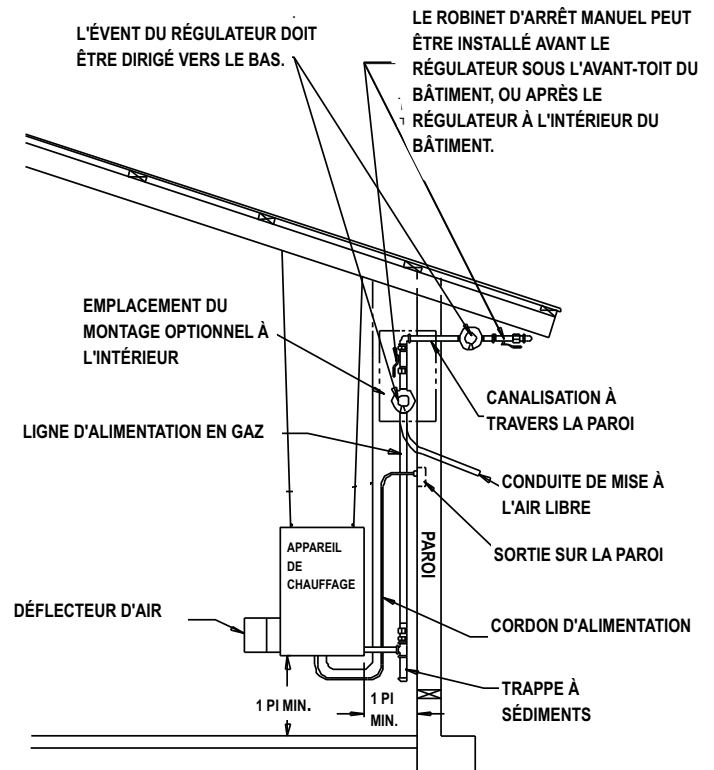

Assemble the tee, nipples and cap together and tighten securely. See Fig. 5. The sediment trap assembly must always be mounted in a vertical position. Make sure pipe thread compound that is resistant to both L.P. gas and natural gas is used in making all connections. **Check all connections for gas leaks using approved gas leak detectors.**

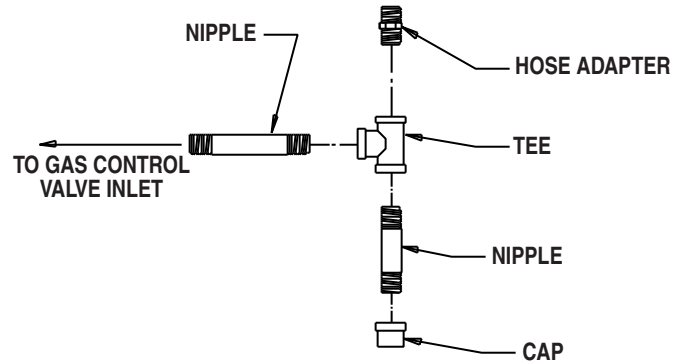
FIG. 5**ASSEMBLAGE DE LA TRAPPE À SÉDIMENTS**

Assemblez le raccord en T, les mamelons et le capuchon et serrez bien. Consultez la figure 5. L'assemblage de la trappe à sédiments doit toujours être monté en **position verticale**. Assurez-vous d'utiliser un composé pour filetage résistant au GPL et au gaz naturel pour tous les raccords. Vérifiez tous les raccords à l'aide d'un détecteur de fuites de gaz homologué.

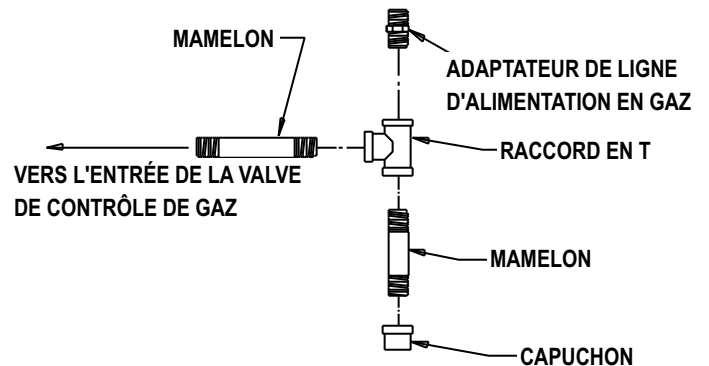
FIG. 5

MANUAL SHUT-OFF VALVE, HOSE AND REGULATOR ASSEMBLY

1. Always use approved pipe thread compound suitable for use with L.P. gas or natural gas on the threaded connections.
2. Assemble the components together according to the figure. This view is to show general assembly of the components only. The regulator must always be mounted so its vent, regardless of location on the regulator, is always pointed downward.
3. Tighten all connections securely.
4. **Check all connections for gas leaks using approved gas leak detectors.**

FIG. 6

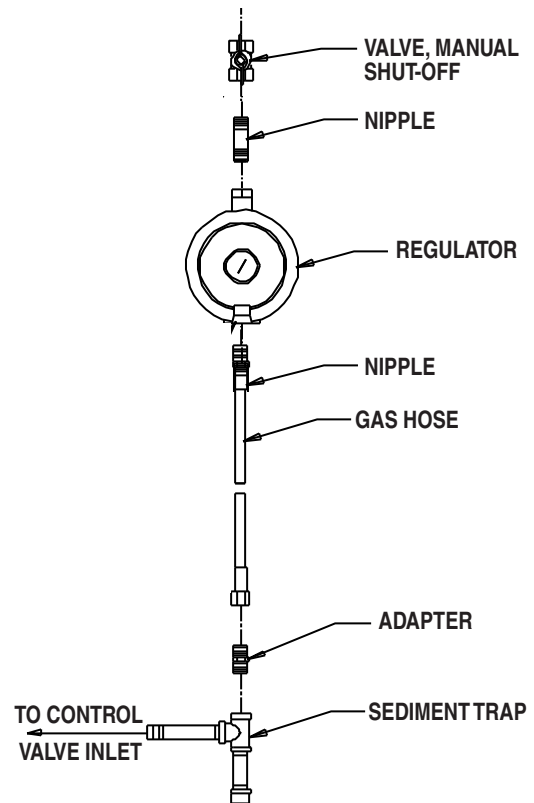

ASSEMBLAGE DU ROBINET D'ARRÊT MANUEL, DU TUYAU ET DU RÉGULATEUR

1. Utilisez toujours un composé pour filetage homologué qui convient au GPL ou au gaz naturel pour les raccords filetés.
2. Assemblez les composants selon la figure. Cette vue ne montre que l'assemblage général des composants. Le régulateur doit toujours être monté de sorte que son évent, quel que soit l'emplacement du régulateur, soit toujours dirigé vers le bas.
3. Serrez fermement tous les raccords.
4. **Vérifiez tous les raccords à l'aide d'un détecteur de fuites de gaz homologué.**

FIG. 6

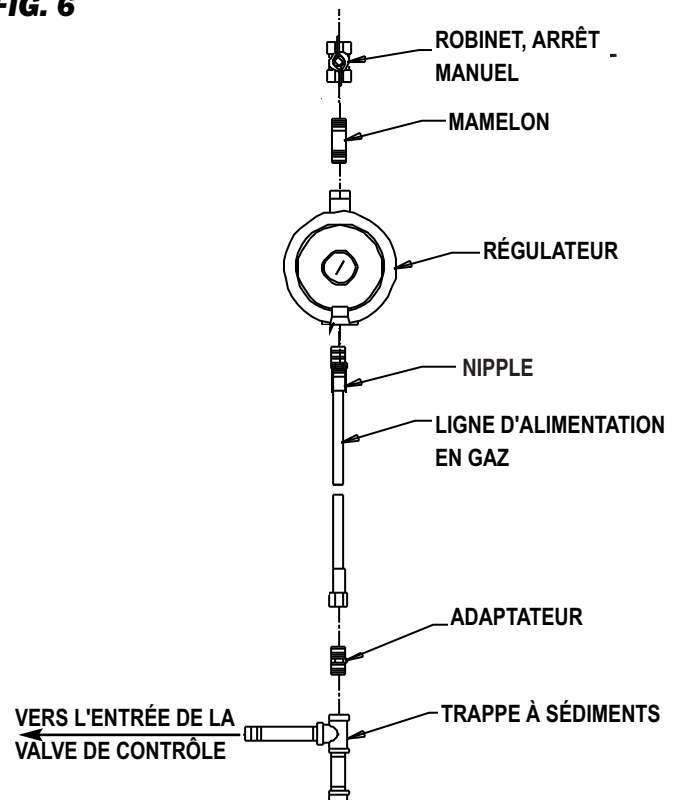

 **WARNING**
Electrical Shock Hazard

- Disconnect the electrical supply before connecting the thermostat to the heater.
- Failure to follow this warning can result in electrical shock, leading to personal injury or death.

1. To Connect the Series Tap Plug Thermostat Kit:

- a. Connect the power cord of the heater to the female side of the plug on the end of the thermostat cord.
- b. Plug the male side of the series tap plug on the thermostat cord into a three-wire (grounded) electrical outlet within the building.

2. To Connect the Direct Wired Thermostat Kit to the Control Box on the Heater:

- a. Open the control box.
- b. Remove the yellow wire connected between the 24 volt output of the transformer and terminal W of the ignition control.

- c. Remove the plastic hole plug at the back or bottom of the control box. Run the wiring of the thermostat kit through this hole.
- d. Connect the black lead of the thermostat kit to the 24 volt output terminal of the transformer.
- e. Connect the white lead of the thermostat kit to terminal W of the ignition control.
- f. Install the strain relief (supplied on thermostat cordset) around the cord at the entry hole of the control box.
- g. Close and latch the control box.
- h. Start the heater and check for proper operation.

INSTALLATION DU THERMOSTAT

 **Avertissement**
Risque de choc électrique

- Débrancher l'alimentation électrique avant de brancher le thermostat de la chaudière.
- Le non-respect de cet avertissement peut provoquer un choc électrique, conduisant à des blessures ou la mort.

1. Branchez le cordon électrique de l'appareil de chauffage sur la prise femelle à l'extrémité du cordon du thermostat.

- a. Branchez le cordon électrique de l'appareil de chauffage sur la prise femelle à l'extrémité du cordon du thermostat.
- b. Branchez la fiche mâle de la prise sur le cordon du thermostat dans une prise de courant à trois broches (mise à la terre) dans le bâtiment

2. Pour connecter l'ensemble thermostat à raccordement direct au boîtier de commande sur l'appareil de chauffage :

- a. Ouvrez le boîtier de commande.
- b. Enlevez le fil jaune branché entre la sortie de 24 V du transformateur et la borne W de la commande d'allumage.
- c. Retirez le bouchon en plastique de l'orifice à l'arrière ou en dessous du boîtier de commande. Faites passer les fils de l'ensemble thermostat à travers cet orifice.
- d. Connectez le fil noir de l'ensemble thermostat à la borne de sortie de 24 V du transformateur.
- e. Connectez le fil blanc de l'ensemble thermostat à la borne W de la commande d'allumage.
- f. Installez la bride de cordon (comprise sur l'ensemble cordon du thermostat) autour du cordon vis-à-vis du trou d'entrée du boîtier de commande.
- g. Fermez et verrouillez le boîtier de commande.
- h. Démarrez l'appareil de chauffage et vérifiez qu'il fonctionne correctement.

Start-Up Instructions

Follow steps 1 - 6 on initial start-up after heater installation by a qualified gas heater service person. For normal start-up, simply turn thermostat above room temperature. The heater will start.

1. Open all manual fuel supply valves and check for gas leaks using approved leak detectors. The gas control valve on the heater has a manual shut-off feature incorporated into the valve assembly. Make sure the indicator on the valve is turned to the “on” position. See Fig. 6.

FIG. 6

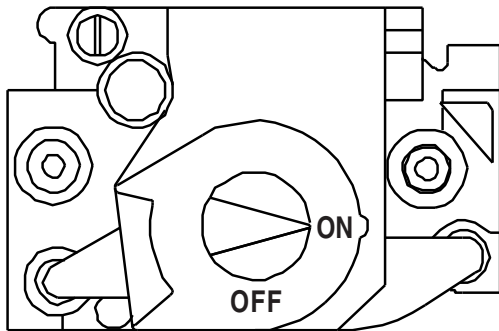

2. Connect the electrical cord to an approved electrical outlet.
3. Set the thermostat (if supplied) to desired room temperature.
4. This heater includes a direct ignition control module for purposes of controlling the timing of the ignition process of the heater as well as monitoring of the safety functions. The control module is contained within the control enclosure. On the control module

is a red light emitting diode (LED). This LED indicates the status of the heater. The LED is visible external of the control enclosure through the viewing window. A constant light from the LED is an indicator that the heater is functioning correctly. Any flash pattern by the LED is indicative that there is a problem in the operation of the heater. Refer to the troubleshooting decal on the access panel at the fan motor end of the heater for assistance in troubleshooting. Only qualified and properly trained personnel shall service or repair the heater.

5. On a call for heat, the motor will start up and run for five (5) seconds. This “pre-purge” is a safety feature and a normal operational characteristic prior to ignition taking place. After five (5) seconds, the igniter will begin to start.

NOTE: It is normal for air to be trapped in the gas hose on new installations. The heater may attempt more than one trial for ignition before the air is finally purged from the line and ignition takes place.

6. The ignition control will make up to three trials for ignition. Each trial for ignition will take approximately ten (10) seconds. The first three trials for ignition will occur within 40 seconds if ignition is not achieved. A 15 minute “wait period” will then begin after the third trial for ignition has taken place. After the 15 minute time span has elapsed, three more trials for ignition will take place. If ignition is not achieved at this final trial, the system will “lock out”, and a three flash pattern will be indicated by the LED.

Shut-Down Instructions

If the heater is to be shut down for cleaning, maintenance or repair, follow steps 1 - 5. Otherwise, simply turn thermostat to “off” or “no heat” for standard shut down.

1. Close all manual fuel supply valves.
2. With the heater lit, allow heater to burn off excess fuel in gas supply hose.

3. Turn the indicator on the gas control to “off”.
4. Turn thermostat to “off” or “no heat” position.
5. Disconnect the heater from the electrical supply.

Instructions de démarrage

Suivez les étapes 1 à 6 pour le démarrage initial une fois que l'appareil de chauffage a été installé par un technicien qualifié en entretien et en réparation des appareils de chauffage au gaz. Pour démarrer normalement l'appareil de chauffage, tournez simplement de bouton de réglage sur une température supérieure à la température de la pièce. L'appareil de chauffage démarre. t.

1. Ouvrez toutes les valves d'alimentation manuelles en gaz et vérifiez qu'aucune fuite de gaz n'est présente à l'aide d'un détecteur de fuites homologué. La valve de commande du gaz sur l'appareil de chauffage comporte une manette de fermeture qui peut se trouver sous un couvercle métallique. Enlevez le couvercle métallique et assurez-vous que la valve est ouverte en vérifiant la position de l'indicateur. Replacez le couvercle métallique. Consultez la figure 6.

FIG. 6

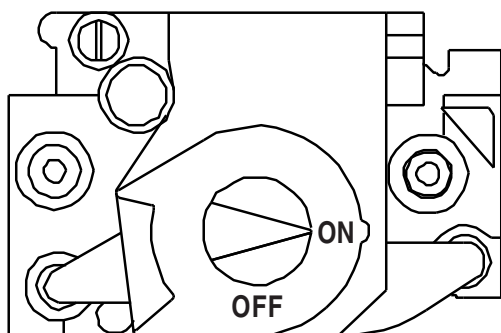

2. Branchez le cordon électrique sur une sortie électrique homologuée.
3. Réglez le thermostat sur la température désirée pour la pièce.
4. L'appareil de chauffage comprend un module de commande d'allumage à surface chaude afin de contrôler son processus d'allumage et de surveiller ses caractéristiques de sécurité. Ce module se trouve à l'intérieur du boîtier de commande. Une diode électroluminescente (DEL) rouge se trouve sur

le module. Ce voyant indique l'état de l'appareil de chauffage. La DEL est visible depuis l'extérieur de la boîte de commande à travers le regard de plastique. Si la DEL est allumée de façon continue, cela indique que l'appareil de chauffage fonctionne correctement. Si la DEL clignote, cela indique un problème de fonctionnement de l'appareil de chauffage. Pour obtenir des conseils de dépannage, consultez l'autocollant à cet effet situé sur le panneau d'accès à l'extrémité de l'appareil de chauffage où se trouve le ventilateur. Seul le personnel qualifié et correctement formé peut effectuer l'entretien de l'appareil de chauffage ou le réparer.

5. Suite à un appel de chaleur, le moteur démarre et tourne pendant 5 secondes, puis s'arrête. Ce prébalayage est une fonctionnalité de sécurité et une caractéristique normale de fonctionnement qui se déroule avant l'allumage. Une fois que le moteur s'est arrêté, l'allumeur chauffe (pendant environ 17 secondes). Une fois cette période de préchauffage écoulée, le moteur redémarre et l'allumage se produit peu après.

REMARQUE : il est normal que de l'air reste emprisonné dans le tuyau de gaz d'un appareil nouvellement installé. Il est possible que l'appareil de chauffage nécessite plus d'une tentative d'allumage avant que l'air soit finalement expulsé de la canalisation et que l'appareil s'allume.

6. La commande d'allumage fera jusqu'à trois tentatives d'allumage. Chaque tentative d'allumage dure environ 20 secondes. Les deux premiers essais d'allumage se produisent dans un intervalle de 40 secondes si l'allumage ne s'est pas effectué. Une période d'attente de 15 minutes commence après la deuxième tentative d'allumage. Une fois la période de 15 minutes écoulée, la troisième et dernière tentative d'allumage a lieu. Si cette dernière tentative ne parvient pas à allumer l'appareil de chauffage, le système se verrouille et le voyant DEL émet une série de trois clignotements à répétition.

Consignes d'extinction

Si l'appareil de chauffage doit être éteint pour être nettoyé, entretenu ou réparé, suivez les étapes 1 à 4. Sinon, réglez le contrôleur du bâtiment en position OFF.

1. Fermez toutes les valves manuelles d'alimentation en gaz.

2. Pendant que l'appareil de chauffage est allumé, laissez-le brûler tout excès de combustible dans la conduite d'alimentation en gaz.
3. Réglez le contrôleur du bâtiment en position OFF.
4. Débranchez l'appareil de chauffage de l'alimentation électrique.

Variable Heat Output

1. Some models of propane (LP) gas or natural gas heaters have a throttle valve for varying heat output located between the gas control valve and gas manifold assemblies. See Fig. 7. **THIS IS NOT A MANUAL GAS SHUT OFF VALVE.**
2. The throttle valve can be adjusted to deliver either minimum heat or maximum heat. When the throttle valve handle is parallel to the gas flow, the valve is completely open to deliver maximum heat output.

FIG. 7

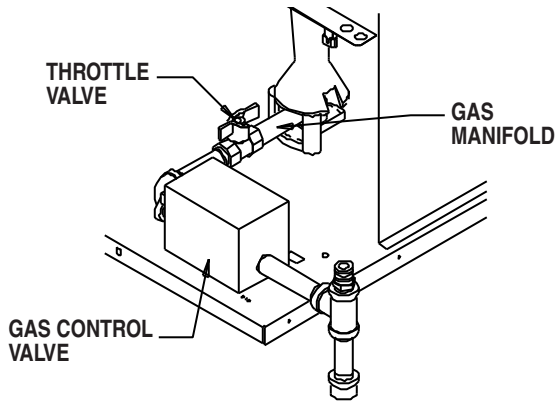

The throttle valve may be adjusted to minimum heat output by turning the handle 90° to gas flow or any position between maximum and minimum settings. See Fig. 8.

FIG. 8

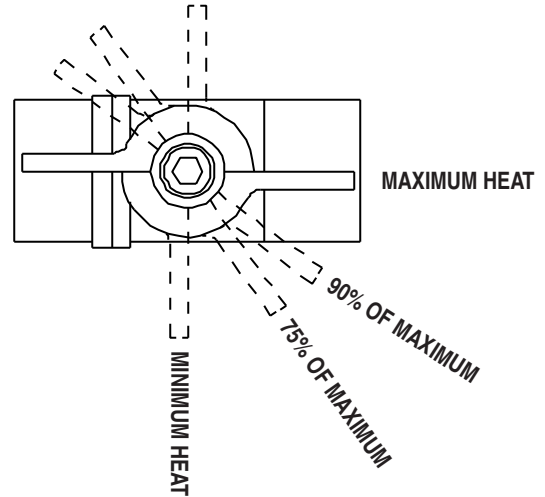

Cleaning Instructions



WARNING Fire, Burn, and Explosion Hazard

- This heater contains electrical and mechanical components in the gas management, safety and airflow systems.
- Such components may become inoperative or fail due to dust, dirt, wear, aging, or the corrosive atmosphere of an animal confinement building.
- Periodic cleaning and inspection as well as proper maintenance are essential to avoid serious injury or property damage.

1. Before cleaning, shut off all gas supply valves and disconnect electrical supply.
2. The heater should have dirt or dust removed periodically:
 - a. After each flock or between building re-population, give the heater a general cleaning using compressed air or a soft brush on its interior and exterior. At this time, dust off the motor case to prevent the motor from over-heating and shutting the heater down.
 - b. At least once a year, give the heater a thorough cleaning. At this time, remove the fan and motor assembly and brush or blow off the fan wheel, giving attention to the individual fan blades. Additionally, make sure the burner air inlet venturi ports and the “throat” of the casting are free of dust accumulation and the area between the heat chamber top and inside case is also free of dust.
 - c. When washing with water, observe and obey the Warning within these Cleaning Instructions. This same Warning is also supplied on the heater.



WARNING

This heater may be washed only on the external case assembly provided:

- A. The heater is disconnected from the electrical supply.
- B. All access panels are securely closed.
- C. Water spray nozzle shall not discharge within 6 feet of the heater.
- D. The water pressure does not exceed 45 PSIG for 10 seconds on each side of heater.
- E. The heater is not reconnected to electrical supply for a minimum of 1 hour or until the heater is thoroughly dry.

Improper cleaning of the heater can cause severe personal injury or property damage due to water and/or cleaning solution:

1. In electrical components, connections and wires causing electrical shock or component failure.
2. On gas control components causing corrosion which can result in gas leaks and fire or explosion from the leak.

Clean internal components of the heater with a soft, dry brush or cloth, or compressed air.

1. Have your gas supplier check all gas piping annually for leaks or restrictions in gas lines. Also, at this time have your gas supplier clean out the sediment trap of any debris that may have accumulated.
2. **The heater's surrounding area shall be kept clear and free from combustible materials, gasoline, and other flammable vapors and liquids.**
3. Regulators can wear out and function improperly. Have your gas supplier check the date codes on all regulators installed and check delivery pressures to the appliance to make sure that the regulator is reliable.
4. Regulators must be periodically inspected to make sure the regulator vents are not blocked. Debris,

insects, insect nests, snow, or ice on a regulator can block vents and cause excess pressure at the appliance.

5. Review all heater markings (ie. warnings, start-up/shutdown, electrical wiring, diagrams, etc.) for legibility. Ensure that none are cut, torn, or otherwise damaged. Any damaged markings must be replaced immediately by contacting L.B. White Co., Inc. Markings are available at no cost.
6. Inspect gas hoses for nicks, cuts, or corroded fittings. Replace the complete gas hose assembly if defects are found.
7. Inspect the heater's electrical connections. Replace any terminals that are corroded.

Service Instructions

GENERAL

WARNING
Burn Hazard

- Heater surfaces are hot for a period of time after the heater has been shut down.
- Allow the heater to cool before performing service, maintenance, or cleaning.
- Failure to follow this warning will result in burns causing injury.

WARNING
Fire and Explosion Hazard

- Do not disassemble or attempt to repair any heater components or gas train components.
- All component parts must be replaced if defects are found.
- Failure to follow this warning will result in fire or explosions, causing property damage, injury, or death.

1. Close the fuel supply valve to the heater and disconnect the electrical supply before servicing unless necessary for your service procedure.
2. Clean the heater's orifice with compressed air or a soft, dry rag. Do not use files, drills, broaches, etc. to clean the orifice hole. Doing so will enlarge the hole, causing combustion or ignition problems. Replace the orifice if it cannot be cleaned properly.

3. The high limit switch can be tested by disconnecting the leads at the component, and jumpering the leads together:
 - Reconnect the electrical supply and open fuel supply valves.
 - If the heater lights, the component is defective and must be replaced.
 - Do not leave the jumper on or operate the heater if the part is defective. Replace the part immediately.
 - An alternate method for checking the components is to perform a continuity check.
4. The air proving switch must not be jumpered. If jumpered, the ignition control will not allow heater operation. Test the air proving switch for continuity. If defective, replace the switch.
5. Open the respective case panel for access to burner or fan related components. Open the control box for access to the ignition control, and transformer.
6. Disconnect the appropriate electrical leads when replacing components.
7. For reassembly, reverse the respective service procedure. Ensure gas connections are tightened securely.
8. After servicing, start the heater to ensure proper operation and check for gas leaks.

MOTOR AND FAN WHEEL ASSEMBLY

1. Remove the motor mounting plate screws and lift the fan and motor assembly from the housing. See Fig. 9.
2. Loosen the square head set screw(s) on the fan wheel.
3. Pull the fan wheel from the motor shaft. Use a wheel puller if necessary.
4. Remove the four (4) nuts securing the motor to the mounting plate.

FIG. 9

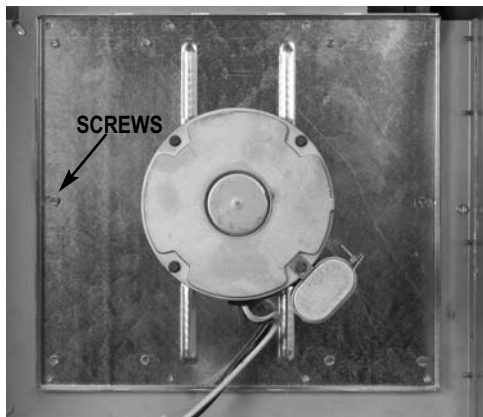

NOTES:a.Fan wheel to motor mount plate spacing must be adjusted to the clearance specified in the table below before tightening the fan wheel to the motor shaft.

b. Make sure that set screw(s) of the fan are on the flats of motor shaft when tightening.

FIG. 10

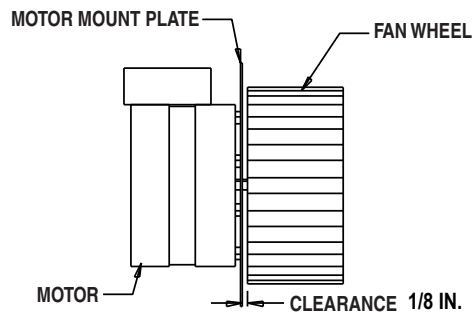

The air proving switch is located on the fan housing at the motor end of the heater. It must work properly to allow an ignition cycle. If the air proving switch contacts are closed before the ignition control starts the fan motor, or do not close on a call for heat after the fan motor starts, ignition will not occur. See Fig. 11.

To service:

- Remove the two (2) sheet metal screws holding the switch with bracket to blower housing.
- Remove the assembly by turning the switch so the paddle on the switch arm can be pulled through the oblong hole on side of fan housing.

FIG. 11

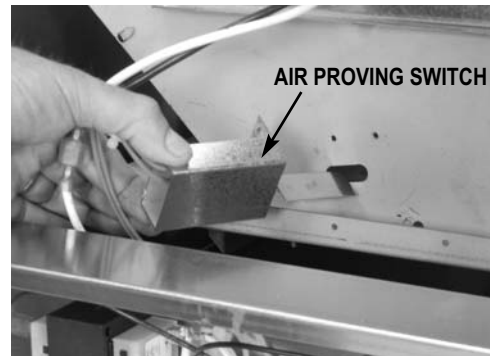

IGNITER AND FLAME SENSOR ASSEMBLY

- Refer to Fig. 12 for servicing of the igniter assembly.
- The igniter/sensor assembly may require cleaning due to accumulations of dust and dirt over a period of time, affecting its ability to ignite fuel gas and sense burner flame. Cleaning will require igniter/sensor removal.
 - If spark appears to be weak, rub the igniter electrode with emery cloth or steel wool to remove any buildup.
 - If the spark appears strong but the heater cycles off, clean the sensor with emery cloth or steel wool to remove any build-up. Also remove dust and dirt from inside the igniter enclosure.
- Ensure the igniter gap is 1/8 - 3/16 in. and the igniter tip is positioned over the burner port according to the illustration below.
- Prior to start up when the heater has not been used for an extended period of time:
 - Clean the sensor of moisture/dust
 - Ensure the top of the burner casting is free of corrosion. Remove corrosion with emery cloth or a wire brush.
 - Corrosion prevents the igniter from sparking to the top of the burner.

FIG. 12

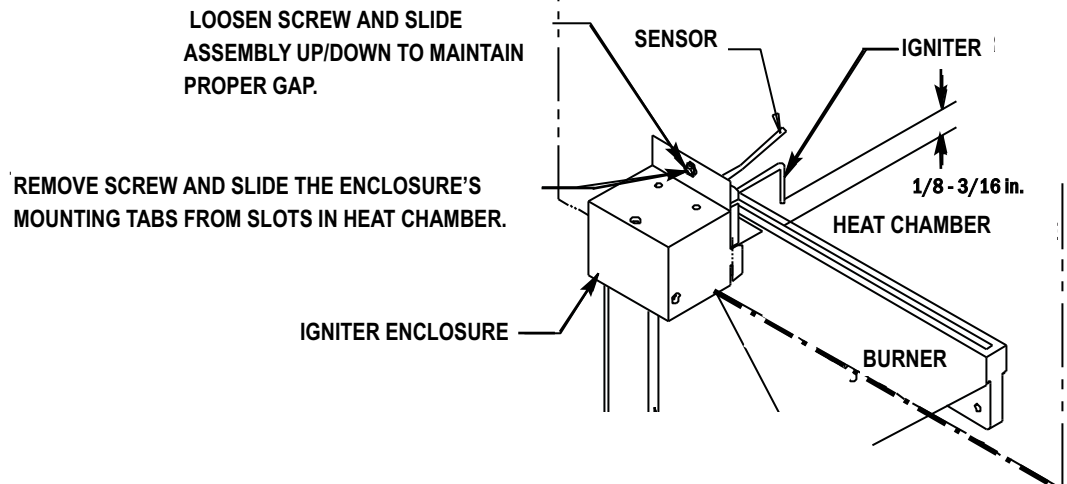

TESTING THE MANUAL RESET HIGH LIMIT SWITCH



WARNING

Fire Hazard

- Do not operate the heater with the high limit switch bypassed.
- Operating the heater a bypass high limit switch may lead to overheating, possibly resulting in a fire, with subsequent damage to the heater, building damage, or loss of livestock.

This heater uses a high limit heat switch for the purpose of over heat protection. The high limit switch is located on the heat chamber, see Fig. 13. It is connected between the ignition control and the gas control valve.

The switch has normally closed contacts. If an overheat condition occurs, the switch contacts will open, thereby opening the circuit to the gas control valve. The high limit switch should be tested a minimum of once per year when the heater is given a thorough cleaning.

1. Remove the switch. Holding the switch by one of its mounting legs, apply a small flame only to the sensing portion on the back of the switch. See Fig. 14. **Do not melt the plastic housing of the switch when conducting this test.**
2. Within a minute, you should hear a pop coming from the switch, which indicates the contacts of the switch have opened. Check for lack of electrical continuity across the switch terminals to verify contacts have opened.

3. Allow the switch cool down for about a minute before firmly pressing the reset button on the switch.
4. Check for electrical continuity across the switch terminals to make sure the contacts have closed.
5. Reinstall the switch back into the heater. Reconnect the heater to its electrical supply. Start the heater and check for proper operation.

FIG. 13

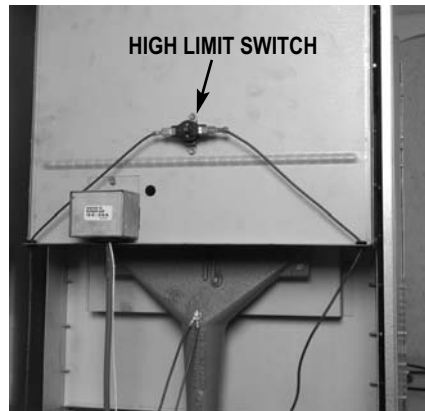
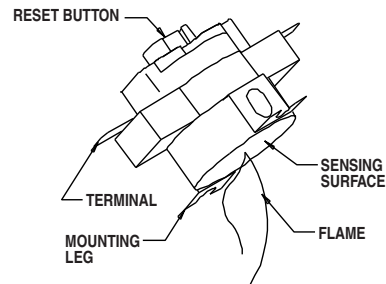

FIG. 14



TRANSFORMER

The transformer reduces 115 VAC to 24 VAC for operation of the the ignition control. Without 24 VAC from the transformer, the red diagnostic light will not be on and the ignition control will not function.

See Fig. 15 for location of the transformer and output terminal reference.

FIG. 15

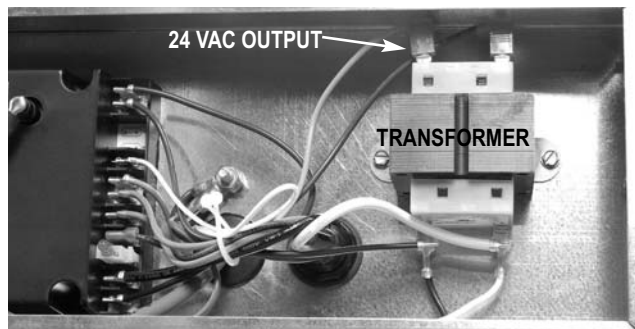

BURNER ORIFICE and GAS CONTROL VALVE

1. Remove the following:
 - Hose and sediment trap from heater.
 - Plastic bushing at gas inlet hole. See Fig. 16.
 - Screws from bracket at inlet of gas control valve. See Fig.16.
 - Burner retaining bolt from underside of base
3. Pivot the valve/manifold assembly as necessary so orifice clears the burner casting venturi port. See Fig. 17.
4. Replace component as needed.

FIG. 16

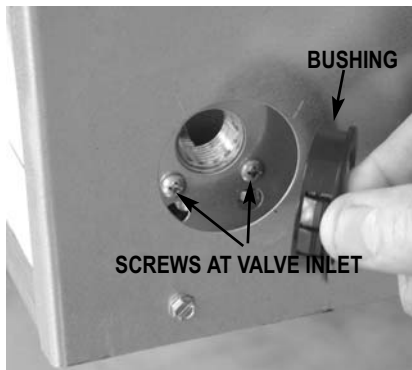
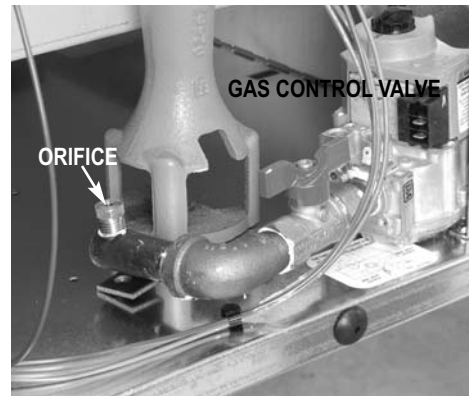

FIG. 17



IGNITION CONTROL

The control sends and receives voltages to operate or verify operation of components. Refer to the following and Fig. 18 to understand the ignition control's terminal designators if doing voltage checks on the control.

- L1:** 115 VAC to control from power supply
- IND:** 115 VAC from control to fan motor
- LED:** Connection for control's diagnostic light wiring harness
- MV:** 24 VAC from control to high limit switch and then to gas control valve.
- PS2:** 24 VAC from air proving switch back to control
- PS1:** 24 VAC from control to air proving switch
- W:** 24 VAC from transformer to control (without this voltage the ignition control will not function)
- FS:** Microamperage from control to flame sensor for proving burner flame
- R:** No terminal
- X:** No terminal
- C/COM:** Control and burner ground

Also refer to "Operation Sequence" within this manual as needed to understand operation of the ignition control during a call for heat.

FIG. 18



Gas Pressure Checks

WARNING

- Do not disassemble the gas control valve.
- Do not attempt to replace any components of the gas control valve.
- The gas control valve must be replaced if any physical damage occurs to the control valve assembly.
- Failure to follow this warning will result in fire or explosions, leading to injury or death to humans, and property damage.

- The following explains a typical procedure to be followed in checking gas pressures.
- The gas pressures will vary depending upon fuel type.
- Consult the dataplate on the heater or page 4 in this manual for specific pressures to be used in conjunction with this procedure.
- Gas pressure measured at the inlet to the gas valve is Inlet Pressure and gas pressure measured at the outlet of the gas valve is Burner Manifold Pressure.

A. Preparation

1. Obtain two pressure gauges capable of reading up to 35 in. W.C.
2. Disconnect the heater from the electrical supply and close the fuel supply valve to the heater inlet.
3. Open the burner access panel.
4. Brush or blow off any dust and dirt on or in the vicinity of the gas control valve.

B. Gauge Installation

1. Locate the inlet and outlet pressure taps, see Fig. 19. Remove the pressure tap plug using a 3/16 in. allen key.

FIG. 19

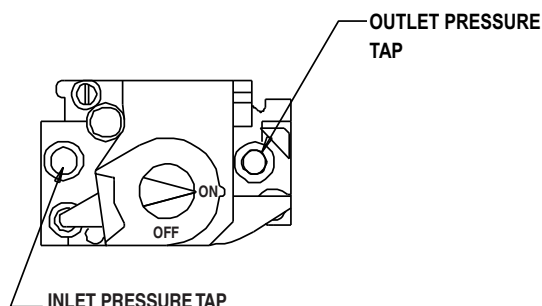
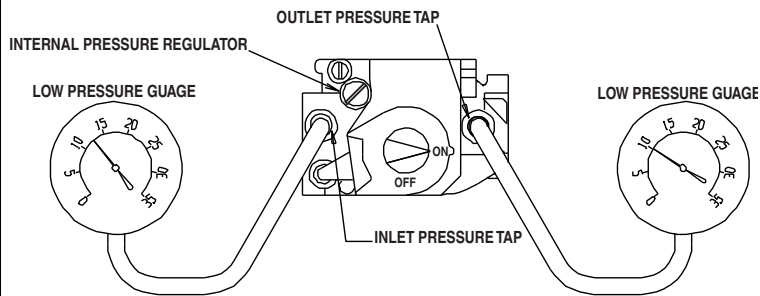

FIG. 20



2. Securely connect a pressure gauge to each pressure tap.
3. Open the fuel supply valves to the heater and reconnect the heater electrical supply.
4. Start the heater

C. Reading Pressures

1. With the heater operating, the pressure gauges should read the pressures specified on the dataplate.
2. Do the readings at the inlet and outlet pressure gauges agree with that specified on the dataplate? If so, then no further checking or adjustment is required. Proceed to section D.
3. If the inlet pressures do not agree with that specified on the dataplate, then the regulator controlling gas pressure to the heater requires adjustment.
4. If the inlet pressures are correct and the burner manifold pressure does not agree with that specified on the dataplate, then the gas control valve's internal pressure regulator requires adjustment. See Fig. 20 for regulator location.

D. Completion

1. Once the proper inlet and burner manifold pressures have been confirmed and/or properly set, close the fuel supply valve to the heater and allow the heater to burn off any gas remaining in the gas supply line.
2. Disconnect the heater from its electrical supply.
3. Remove the gauges and connecting hoses.
4. Install pressure tap plugs and tighten securely. Check for gas leaks.

Troubleshooting Instructions

READ THIS ENTIRE SECTION BEFORE BEGINNING TO TROUBLESHOOT PROBLEMS.

 **WARNING**
Electrical Shock and Burn Hazard

- Do not attempt to service or repair this heater unless you are a properly trained and qualified gas heater service person.
- Troubleshooting this system may require operating the unit with line voltage present and gas on. Use extreme caution when working on the heater.
- Failure to follow this warning may result in property damage, personal injury or death.

The troubleshooting flow charts in this section provide systematic procedures for isolating heater problems. Refer to the Component Testing section of this Service Guide for general instructions on performing voltage and continuity checks as well as evaluation of specific components as indicated by these charts. Refer to the appropriate wiring diagram for assistance in performing voltage and continuity checks. Refer to the Service section for gas pressure checks and adjustments as indicated by the flow charts.

TEST EQUIPMENT REQUIRED

The following pieces of test equipment will be required to troubleshoot this system with minimal time and effort.

- **Digital Multimeter** - for measuring voltage and resistance.
- **Low Pressure Gauge** - (L.B. White Part No. 00764) for checking inlet and manifold pressures of the gas control valve against dataplate rating.

INITIAL PREPARATION

- Visually inspect heater for apparent damage.
- Check all wiring for loose connections and worn insulation.

Refer to the system operation sequence in this section to gain an understanding as to how the heater operates. Understanding the operation sequence of the ignition module and related components is essential as it will relate directly to problem solving provided by the flow charts.

The ignition control module is self-diagnostic. The red light on the module will flash a specific pattern depending upon the problem which is diagnosed. To effectively use the flow charts, you must first identify what the problem is by the flashing pattern of the L.E.D. (light emitting diode) diagnostic light. If the light is flashing, the flash pattern will be followed by a pause and then a repeat of the flash pattern until the problem is corrected.

Problems	Page
L.E.D. Diagnostic light <u>not</u> on during a call for heat	27
L.E.D. diagnostic light flashing:	
A. One Time	28
B. Two Times	28
C. Three Times	29
D. Four Times	29
E. Five Times	29

Components should be replaced only after each step has been completed and replacement is suggested in the flow chart. Refer to the Servicing sections as necessary to obtain information on disassembly and replacement procedures of the component once the problem is identified by the flow chart.

SPARK IGNITION OPERATION SEQUENCE:

- 115 volts is sent to transformer and to ignition control terminal L1.
- 24 volts is sent from transformer to the thermostat.
- A call for heat occurs.
- Thermostat returns 24 volts to ignition control terminal W.
- Red light on ignition control is illuminated.
- Ignition control performs an internal safe start check.
 - Internal components are tested.
 - Ignition control sends 24 volts from terminal PS1 to the air proving switch.
- Ignition control begins safety lockout timing.
- Ignition control sends 115 volts from terminal IND to start the fan motor for prepurge.
 - Air proving switch is checked for proper operation.
 - Air proving switch closes and 24 volts are returned to ignition control terminal PS2.
- Ignition control powers the igniter and igniter sparks.
- Ignition control sends 24 volts to gas control through high limit switch.
- Ignition occurs.
 - Igniter continues to spark until flame proving occurs.
 - Igniter spark is discontinued.
 - Gas valve stays open.
- Room warms to desired temperature.
 - Thermostat is satisfied.
 - Heater shuts down.
- Process begins again on call for heat.

MULTIPLE IGNITION TRIAL SEQUENCE

- First trial for ignition takes approximately 10 seconds
- Two more trials for ignition will occur.
 - Second and third trial follow immediately if first trial fails.
- Ignition control starts a 15 minute “Wait” period to allow ignition interruption to pass.
- Ignition control repeats 3 Ignition attempts after 15 minute wait period
- If ignition control does not prove flame after third Trial, the control goes into safety lockout (3 flash pattern).
 - Igniter shuts down
 - Fan motor stops
 - Gas valve closes
- To retry ignition, reset the ignition system by:
 - Unplugging the heater and plug it back in
 - OR –
 - Turn Thermostat to “Off” or “No Heat” and then back to above room temperature

LED constant on → Normal operation.

Problem

Red LED not on during a call for heat.

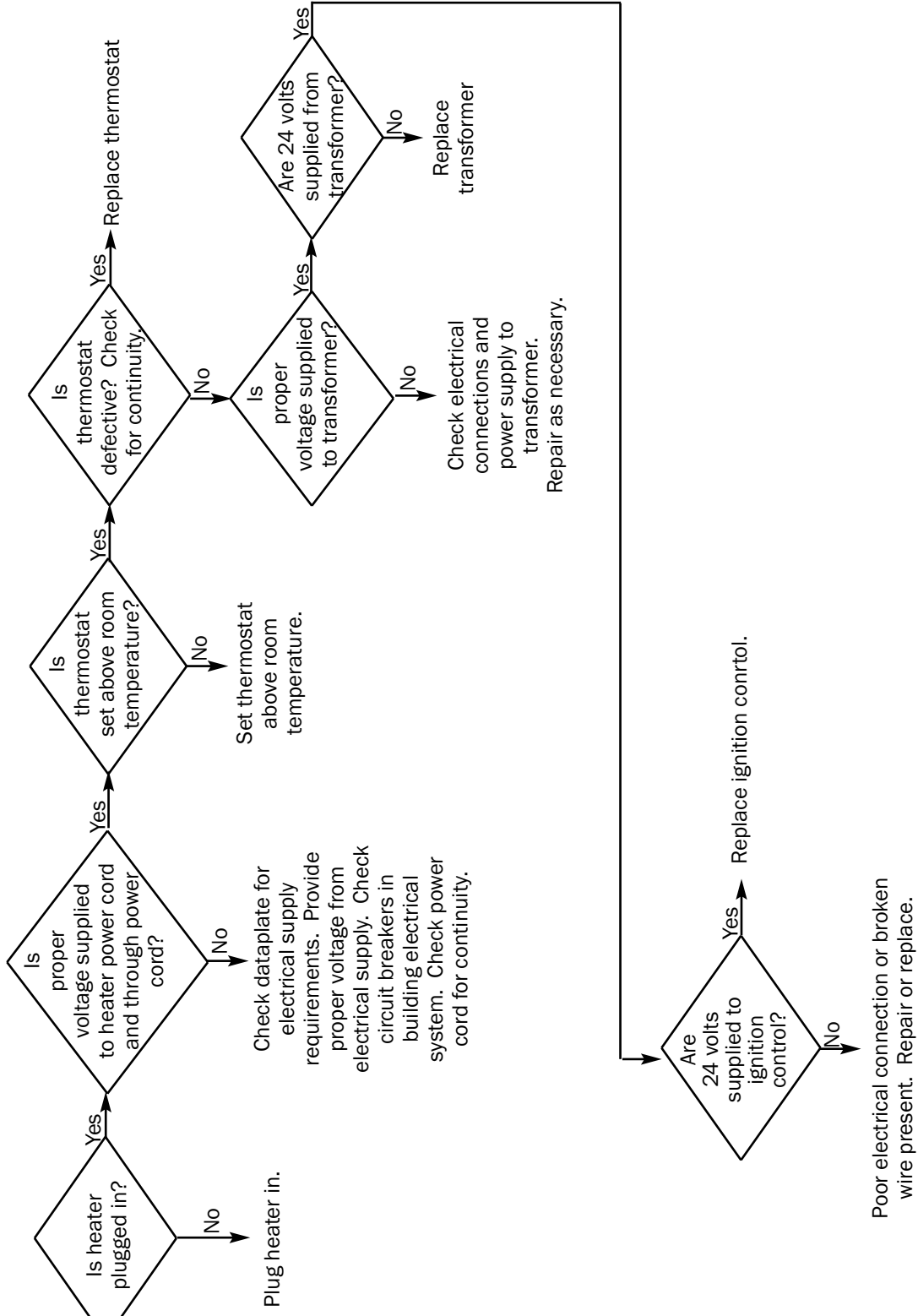

One Time

Flash pattern begins immediately, fan motor does not run. Heater does not light.

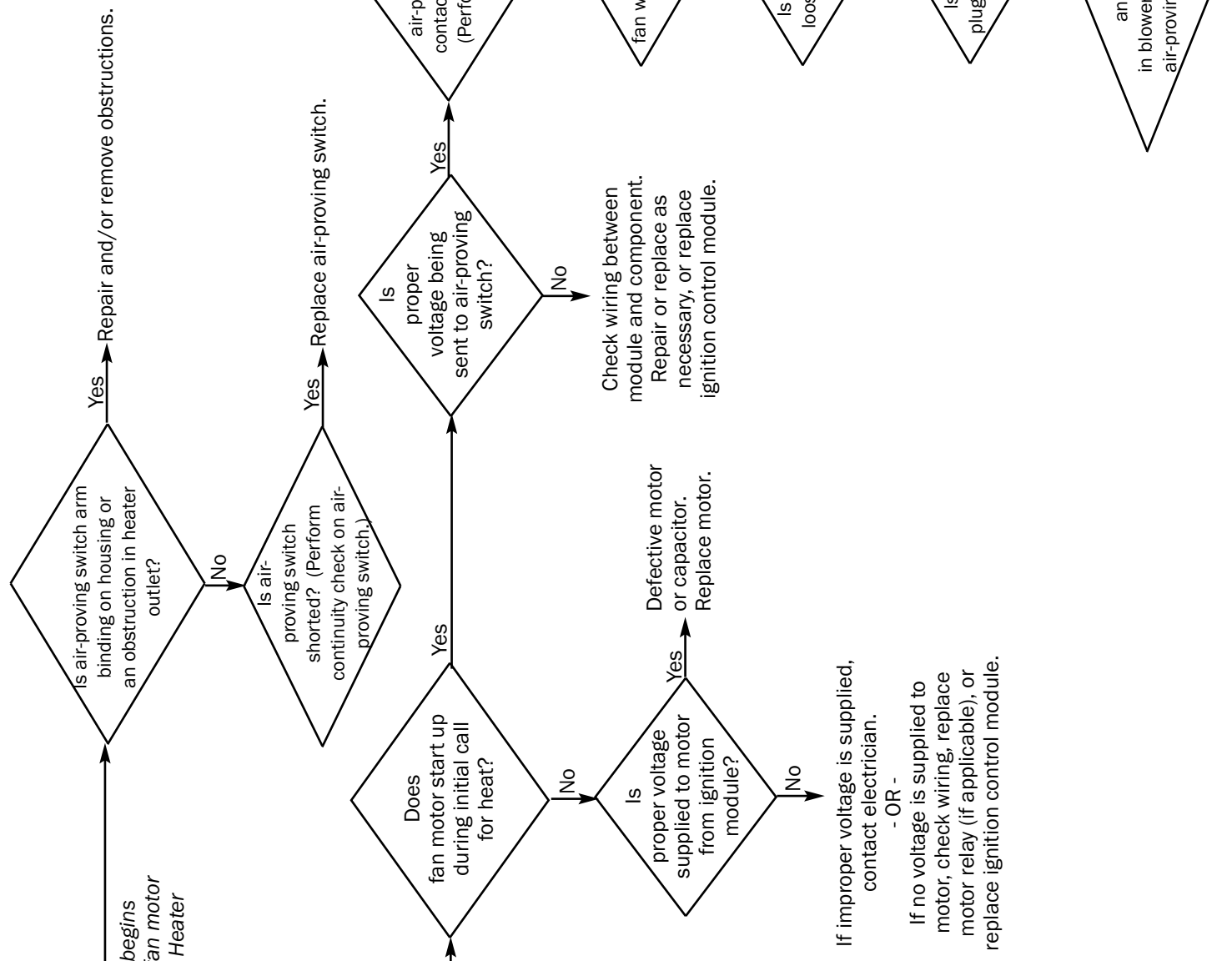

Two Times

Lack of air proving in fan section.

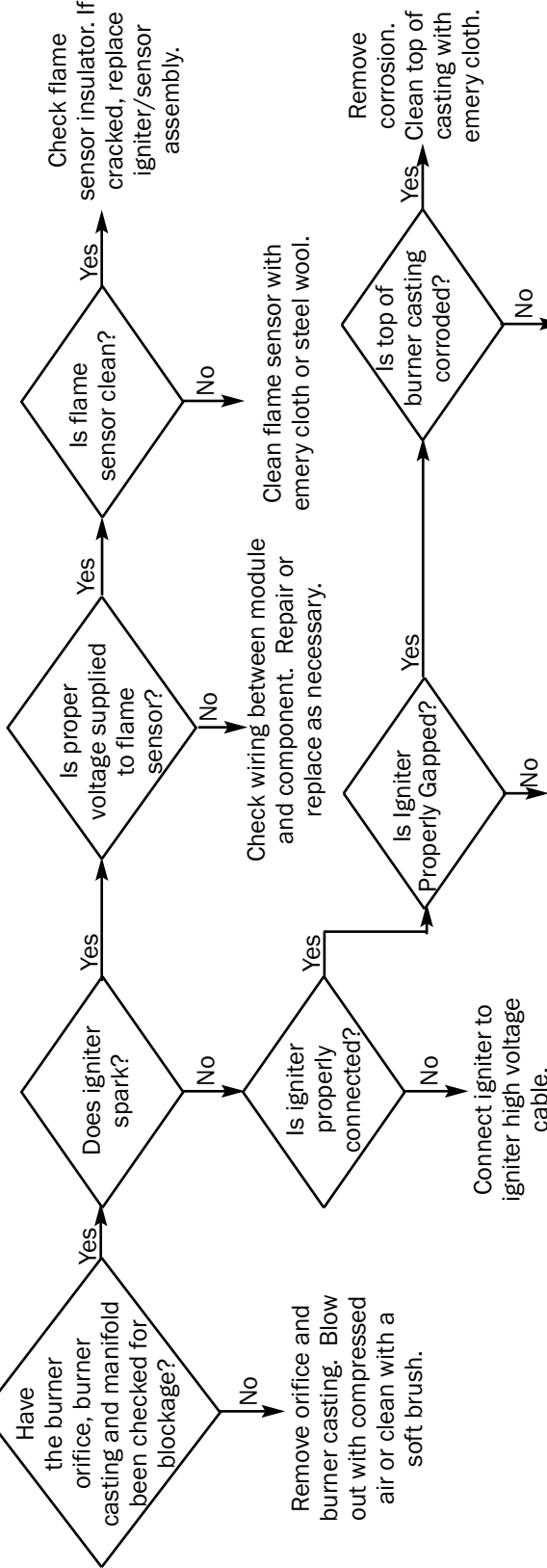
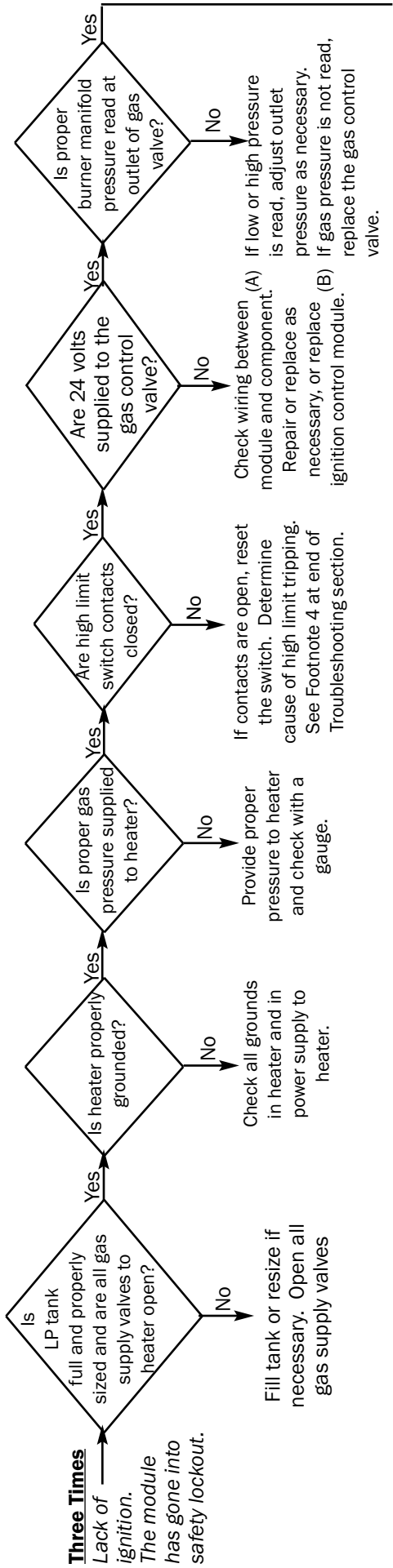

Close gas supply valve to heater.
 Disconnect ignitor cable from ignition control. Place the tip of a screwdriver about 1/8 in. from where igniter cable was connected to control. Turn heater on. If spark does not jump from ignition control to screwdriver, replace ignition control. If spark is seen, replace the igniter/sensor assembly

Four Times — Flame Sense Degradation. Clean sensor, check all ground connections.

Five Times — If DSI board does not reset, then replace the board. (Internal board fault.) If DSI board resets, then have qualified electrician check power source for power quality problems. (Frequency, line noise, line spikes, loose connections, too small wire gauge.)

Electrical Connection and Ladder Diagram

CAUTION

Always refer to the heater's electrical connection diagram when servicing to avoid wiring errors and heater malfunction. Check for proper operation after servicing.

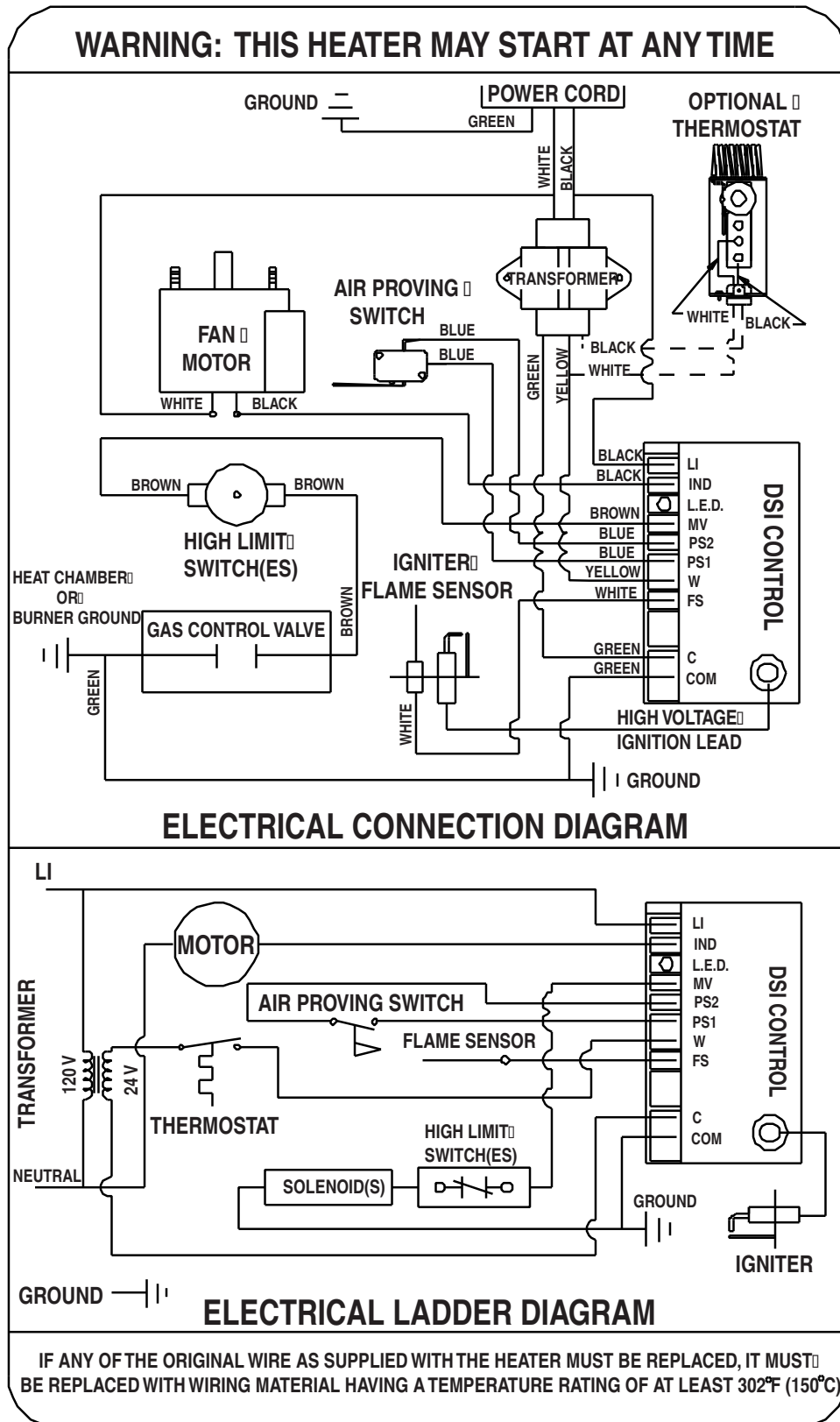

Heater Component Function

Air Proving Switch

Safety device used to insure that the proper air flow is being achieved before the gas valve is opened.

Burner

Cast iron component used to channel gas and provide an area at which the fuel may ignite.

Burner Orifice

Brass metering device used to feed gas to burner at a specific rate.

Fan Housing

Chamber used for compressing air for efficient air movement.

Fan Wheel

Component used in conjunction with the motor and fan housing to pull the hot air from heater and blow it into room for heating (also known as a “squirrel cage”).

Gas Control Valve

A device which consists of a low pressure regulator and electrical solenoids which are used for the control of gas flow to the burner assembly. A feature of the control is a built in gas shut off which is used to isolate the heater from its gas supply when servicing.

Gas Hose

Flexible connector used to convey gas from supply line in building to heater.

Heat Chamber

Metal “fire box” within the appliance that provides an area where burner flame mixes with combustion air thereby providing heat.

High Limit Switch

Safety device wired into the control system which is used to break an electrical circuit to the gas control valve in event of overheat situation.

Ignition Control Module

Controls the ignition sequence and operation of the heater as well as monitoring the safety services. A major service feature is the board’s ability to diagnose component and flame failure by means of a diagnostic light located within the module. This light will provide a specific flash pattern repetitively, depending on the type of component failure that has occurred.

Igniter/Flame Sensor Assembly

This assembly consists of two components mounted adjacent on the same bracket.

- Spark Igniter: Electrical ignition device used on automatic ignition control systems. Ignites gas by a spark.
- Flame Sensor: Also known as a flame rod or flame probe, this device works in conjunction with the ignition module in proving that burner flame has been established.

Motor

Electric device used to force preheated air through the heater and to circulate heat within a certain area. Converts electrical energy into mechanical energy.

Regulator

The heart of any gas supply installation. Used to deliver a working pressure to the appliance under varying conditions in tank pressure.

Thermostat

Electrical device used as an automatic “on/off” switch which will respond to changes in temperature in a certain area. Can be wired so contacts in the thermostat open or close on temperature increase or decrease.

Throttle Valve

Manually adjustable component used to increase or decrease the flow of gas to the burner. The throttle valve is located between the gas control valve and burner assembly.

Transformer

This device is responsible for reducing a higher incoming voltage (normally 115 V.A.C.) to a lower outgoing voltage. The lower voltage (24 V.A.C.) is essential to operate the ignition control module.

Parts Identification

PARTS SCHEMATIC

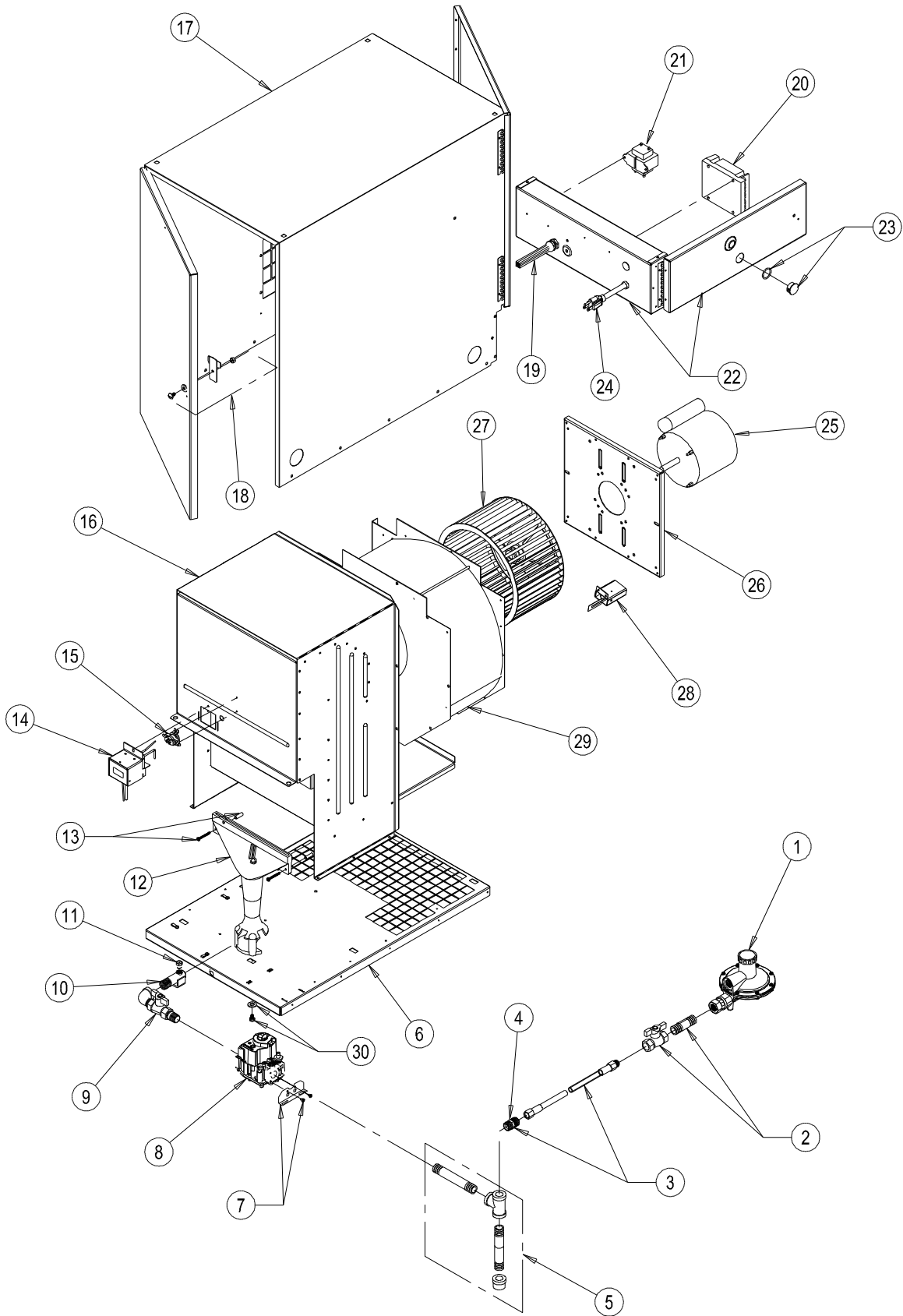

Parts Identification

PARTS LIST

Item	Description	Part Number
1	Regulator, LP Gas, 2nd Stage, Vent Over Outlet	06553*
	Regulator, LP Gas, 2nd Stage, Vent Over Side	06665*
	Regulator, Natural Gas (5 PSIG Inlet, 13.5 Outlet)	24414*
2	Manual shut off valve with nipple	03399*
3	Hose, 1/2 in. ID x 10 ft. with Adapter	20714*
4	Adapter, Hose, 1/2 NPT x 1/2 NPS	25873*
5	Sediment Trap	00815
6	Base	570000
7	Bracket with screws	570141
8	Gas control valve, LP Gas	522076
	Natural Gas	522078
9	Gas assembly with throttle valve, LP gas	570019
	Natural gas	570020
	fixed rate (non-variable, LP gas or Natural gas)	570171
10	Manifold	509291
11	Burner orifice, LP gas	570053
	Natural gas	570054
12	Burner with mounting hardware	570655
13	Burner mounting hardware	570211
14	Igniter and sensor assembly	22473
15	High limit switch	505566
16	Heat chamber	570200
17	Case assembly with doors and latches, galvanized, variable rate, LP gas	570789
	galvanized, variable rate, Natural gas	570790
	galvanized, fixed rate, LP gas	570239
	galvanized, fixed rate, Natural gas	570240
	tri-shield, variable rate, LP gas	573248
	tri-shield, variable rate, Natural gas	573249
	tri-shield, fixed rate, LP gas	573246
	tri-shield, fixed rate, Natural gas	573247
18	Latch kit, case and control box	570228
19	Wire kit, with harness (all heater wirng)	570103
20	Ignition control	524900
21	Transformer, 120/24 volt	509615
22	Control box assembly with cover, galvanized	570512
	tri-shield	573245
23	Window plug with o-ring	570002
24	Power cord, 10 ft.	520133
25	Motor, 1/3 hp., ball bearing	520169
26	Motor mount	570251
27	Fan wheel	570481
28	Air proving switch	24157
29	Fan housing with air proving switch, and motor mount	24167
30	Bolt and washer	25866

* Accessory

Warranty Policy

HEATER

L.B. White Co., Inc. warrants that the component parts of its heater are free from defects in material and workmanship, when properly installed, operated, and maintained in accordance with the Installation and Maintenance Instructions, safety guides and labels contained with each unit. If, **within 12 months from the date of purchase by the end user**, any component is found to be defective, L.B. White Co., Inc. will at its option, repair or replace the defective part or heater, with a new part or heater, F.O.B., Onalaska, Wisconsin.

A warranty card on file at L.B. White will automatically qualify a unit and its component parts for warranty consideration. If a warranty card is not on file, a copy of the bill of sale will be required to establish warranty qualification. If neither is available, the warranty period will be 12 months from date of shipment from L.B. White.

PARTS

L.B. White Co., Inc. warrants that replacement parts purchased from the company and used on the appropriate L.B. White equipment are free from defects both in material and workmanship for **12 months from the date of purchase by the end user**. Warranty is automatic if a component is found defective within 12 months of the date code marked on the part. If the defect occurs more than 12 months later than the date code but within 12 months from the date of purchase by the end user, a copy of a bill of sale will be required to establish warranty qualification.

The warranty set forth above is the exclusive warranty provided by L.B. White, and all other warranties, including any implied warranties or merchantability or fitness for a particular purpose, are expressly disclaimed. In the event any implied warranty is not hereby effectively disclaimed due to operation of law, such implied warranty is limited in

duration to the duration of the applicable warranty stated above. The remedies set forth above are the sole and exclusive remedies available hereunder. L.B. White will not be liable for any incidental or consequential damages directly or indirectly related to the sale, handling or use of the equipment, and in any event L.B. White's liability in connection with the equipment, including for claims based on negligence or strict liability, is limited to the purchase price.

Some states do not allow limitations on how long an implied warranty lasts, so the above limitation may not apply to you. Some states do not allow the exclusion or limitation of incidental or consequential damages, so the above limitation or exclusion may not apply to you. This warranty gives you specific legal rights, and you may also have other rights which vary from state to state.

Replacement Parts and Service

Contact your local L.B. White dealer for replacement parts and service or call the L.B. White Co., Inc. at 1-800-345-7200 for assistance. Be sure that you have your heater model number and configuration number when calling.

