



# Owner's Manual and Instructions

## Guardian Agricultural Animal Confinement Building Heaters



MODELS	MJ/HOUR	FUEL
AD100	100	Available in either Propane Vapor Withdrawal or Natural Gas Configurations.
AD250	250	

Certification by:



## Congratulations!

You have purchased the finest agricultural building heater available.

Your new L.B. White heater incorporates the benefits from the most experienced manufacturer of heating products using state-of-the-art technology.

We, at L.B. White, **thank you** for your confidence in our products and welcome any suggestions or comments you may have...call us at +1-608-783-5691.

### ATTENTION ALL USERS

This heater has been designed and developed specifically for use as a direct-fired circulating heater for agricultural animal confinement buildings. The heater has been evaluated and certified by the Australian Gas Association. The heater must be installed in accordance with the Australian Gas Installation Standard AS/NZS 5601.

This heater is approved for outdoor installation only on animal confinement buildings. The appropriate L.B.White outdoor mounting kits must be used. Refer to the outdoor mounting kit instructions for hanging height and proper clearances of heater to ground.

If you are considering using this product for any application other than its intended use, then please contact your fuel gas supplier, or the L.B. White Co., LLC



World Provider - Innovative Heating Solutions

150-30477 REV.B

411 Mason Street, Onalaska, WI USA 54650 ■ 001 608 783 5691 ■ 001 608 783 6115, fax ■ www.lbwhite.com



### GENERAL HAZARD WARNING

- Failure to comply with the precautions and instructions provided with this heater, can result in:
  - Death
  - Serious bodily injury or burns
  - Property damage or loss from fire or explosion
  - Asphyxiation due to lack of adequate air supply or carbon monoxide poisoning
  - Electrical shock
- This heater is approved for industrial use only
- Read this Owner's Manual before installing or using this product.
- Only authorized service people shall repair or install this heater.
- Save this Owner's Manual for future use and reference.
- Owner's Manuals and replacement labels are available at no charge. For assistance, contact L.B. White at +1-608-783-5691.



### WARNING

- Proper gas supply pressure must be provided to the inlet of the heater.
- Refer to rating plate for proper gas supply pressure.
- Gas pressure in excess of the maximum inlet pressure specified at the heater inlet can cause fires or explosions.
- Fires or explosions can lead to serious injury, death, building damage or loss of livestock.
- Gas pressure below the minimum inlet pressure specified at the heater inlet may cause improper combustion.
- Improper combustion can lead to asphyxiation or carbon monoxide poisoning and therefore serious injury or death to humans and livestock.



### WARNING

#### Fire and Explosion Hazard

- Not for home or recreational vehicle use.
- Installation of this heater in a home or recreational vehicle may result in a fire or explosion.
- Fire or explosions can cause property damage or loss of life.

### FOR YOUR SAFETY

Do not store or use gasoline or other flammable vapors, liquids, or materials in the vicinity of this or any other appliance.

### FOR YOUR SAFETY

If you smell gas:

1. Open windows.
2. Don't touch electrical switches.
3. Extinguish any open flame.
4. Immediately call your gas supplier.



### WARNING

#### Fire and Explosion Hazard

- Do not modify this appliance.
- Keep solid combustibles a safe distance away from the appliance.
- Solid combustibles include wood or paper products, feathers, straw, and dust.
- Do not place articles against this appliance.
- Do not spray aerosols in the vicinity of this appliance while it is in operation.
- Do not use the appliance in spaces which contain or may contain volatile or airborne combustibles, or aerosols.
- Failure to follow these instructions may result in a fire or explosion.
- Fire or explosions can lead to property damage, personal injury or loss of life.
- Do not use or store flammable materials in or near this appliance.



# Table of Contents

<b>SECTION</b>	<b>PAGE</b>
General Information .....	3
Heater Specifications .....	4
Safety Precautions .....	5
Installation Instructions .....	7
General .....	7
Sediment Trap Assembly .....	9
Thermostat Installation .....	9
Start-Up Instructions .....	10
Shut-Down Instructions .....	10
Cleaning Instructions .....	11
Maintenance Instructions .....	11
Service Instructions .....	12
General .....	12
Motor and Fan Wheel Assembly .....	12
Air Proving Switch .....	13
Manual Reset High Limit Switch .....	13
Ignition Controller .....	14
Relay .....	14
Transformer .....	14
Reset Switch .....	14
Igniter and Flame Sensor .....	15
Gas Control Valve and Burner Orifice .....	15
Gas Pressure Checks .....	16
Troubleshooting Guide .....	17
Electrical Connection and Ladder Diagram .....	22
Heater Component Function .....	23
Parts Identification	
AD100 Parts Schematic and Parts List .....	27 and 25
AD250 Parts Schematic and Parts List .....	26 and 27
Warranty Policy .....	28
Replacement Parts and Service .....	28

## General Information

This Owner's Manual includes all options and accessories commonly used on this heater. However, depending on the configuration purchased, some options and accessories may not be included.

When calling for technical service assistance, or for other specific information, always have model number, configuration number and serial number available. This information is contained on the dataplate. The dataplate is located on the exterior of the burner end door.

This manual shall remain with the end user. The manual will instruct the end user in the operation and care of the heater. An authorized installer shall review this manual with the end user to ensure full understanding of the heater and how it functions.

**The gas supply line installation, installation of the heater, and repair and servicing of the heater requires continuing expert training and knowledge of gas heaters and should not be attempted by anyone who is not authorized. See page 6**

Contact your local L.B. White distributor or the L.B. White Co., LLC for assistance, or if you have any questions about the use of the equipment or its application.

The L.B. White Co., LLC has a policy of continuous product improvement. It reserves the right to change specifications and design without notice.

# Heater Specifications

SPECIFICATIONS		Model	
		AD100	AD250
Maximum Input per Hour (MJ)		100	250
Ventilation Air Required to Support Combustion (m <sup>3</sup> /hour)		679	1,885
Burner Manifold Pressure (kPa)	<b>PROPANE GAS</b>	2.5	
	<b>NATURAL GAS</b>	0.90	0.75
Inlet Gas Supply Pressure Acceptable at the Inlet of the Heater for Purpose of Input Adjustment (kPa)	<b>PROPANE GAS</b> <b>MAX.</b>	3.40	
	<b>MIN.</b>	2.75	
	<b>NATURAL GAS</b> <b>MAX.</b>	3.40	
	<b>MIN.</b>	1.13	
Burner Injector Size (mm)	<b>PROPANE GAS</b>	2.9	4.4
	<b>NATURAL GAS</b>	4.6	7.0
Motor Characteristics		Ball Bearing	
		150 Watts 1300 RPM	249 Watts 1150 RPM
Electrical Supply (Volts/Hz/Phase)		220-240/50/1	
Amp Draw (Starting Amps Includes Igniter)	<b>STARTING</b>	2.0	3.9
	<b>CONTINUOUS OPERATION</b>	1.2	2.6
Dimensions L x W x H(cm)		75 x 36 x 46	78 x 46 x 72
		<b>TOP</b>	0.3 m
		<b>SIDES</b>	0.3 m
Minimum Safe Distances From Nearest Combustible Materials	<b>BACK</b>	0.3 m	
	<b>BLOWER OUTLET</b>	3.0 m	
Minimum Safe Distances From the Heater to the Gas Supply		L.P. Gas – 1.83 m Natural Gas – N/A	

# Safety Precautions

## **WARNING** **Asphyxiation Hazard**

- Do not use this heater for heating human living quarters.
- Do not use in unventilated areas.
- The flow of combustion and ventilation air must not be obstructed.
- Proper ventilation air must be provided to support the combustion air requirements of the heater being used.
- Refer to the specification section of the heater's Owner's Manual, heater dataplate, or contact the L.B. White Company to determine combustion air ventilation requirements of the heater.
- Lack of proper ventilation air will lead to improper combustion.
- Improper combustion can lead to carbon monoxide poisoning in humans leading to serious injury or death. Symptoms of carbon monoxide poisoning can include headaches, dizziness and difficulty in breathing.
- Symptoms of improper combustion affecting livestock can be disease, lower feed conversion, or death.

## **FUEL GAS ODOR**

**LP gas and natural gas have man-made odorants added specifically for detection of fuel gas leaks. If a gas leak occurs, you should be able to smell the fuel gas. THAT'S YOUR SIGNAL TO GO INTO IMMEDIATE ACTION!**

- Do not take any action that could ignite the fuel gas. Do not operate any electrical switches. Do not pull any power supply or extension cords. Do not light matches or any other source of flame. Do not use your telephone.
- Get everyone out of the building and away from the area immediately.
- Close all propane (LP) gas tank or cylinder fuel supply valves, or the main fuel supply valve located at the meter if you use natural gas.
- Propane (LP) gas is heavier than air and may settle in low areas. When you have reason to suspect a propane leak, keep out of all low areas.
- Natural gas is lighter than air and can collect around rafters or ceilings.
- Use your neighbor's phone and call your fuel gas supplier and your fire department. Do not re-enter the building or area.
- Stay out of the building and away from the area until declared safe by the firefighters and your fuel gas supplier.
- **FINALLY**, let the fuel gas service person and the firefighters check for escaped gas. Have them air out the building and area before you return. Qualified service people must repair the leak, check for further leakages, and then relight the appliance for you.

## **ODOR FADING -- NO ODOR DETECTED**

- **Some people cannot smell well. Some people cannot smell the odor of the man-made chemical added to propane (LP) or natural gas. You must determine if you can smell the odorant in these fuel gases.**
- Learn to recognize the odor of propane (LP) gas and natural gas. Local propane (LP) gas dealers and your local natural gas supplier (utility) will be more than happy to give you a "scratch and sniff" pamphlet. Use it to become familiar with the fuel gas odor.
- Smoking can decrease your ability to smell. Being around an odor for a period of time can affect your sensitivity to that particular odor. Odors present in animal confinement buildings can mask fuel gas odor.
- **The odorant in propane (LP) gas and natural gas is colorless and the intensity of its odor can fade under some circumstances.**
- If there is an underground leak, the movement of gas through the soil can filter the odorant.
- Propane (LP) gas odor may differ in intensity at different levels. Since propane (LP) gas is heavier than air, there may be more odor at lower levels.
- **Always be sensitive to the slightest gas odor.** If you continue to detect any gas odor, no matter how small, treat it as a serious leak. Immediately go into action as discussed previously.

## **ATTENTION -- CRITICAL POINTS TO REMEMBER!**

- Propane (LP) gas and natural gas have a distinctive odor. Learn to recognize these odors. (Reference Fuel Gas Odor and Odor Fading sections above.)
- If you are not authorized in repair and service of propane (LP) gas and natural gas fueled heaters, then do not attempt to light heater, perform service or repairs, or make any adjustments to the heater on propane (LP) gas or natural gas fuel system.
- Even if you are not authorized in the service and repair of the heater, ALWAYS be consciously aware of the odors of propane (LP) gas and natural gas.
- A periodic "sniff test" around the heater or at the heater's joints; i.e. hose, connections, etc., is a good safety practice under any conditions. If you smell even a small amount of gas, CONTACT YOUR FUEL GAS SUPPLIER IMMEDIATELY. DO NOT WAIT!

# Safety Precautions

1. Do not attempt to install, repair, or service this heater or the gas supply line unless you are authorized and have continuing expert training and knowledge of gas heaters.
  - a. To be an authorized gas heater service person, you must have sufficient training and experience to handle all aspects of gas-fired heater installation, service and repair. This includes the task of installation, troubleshooting, replacement of defective parts and testing of the heater. You must be able to place the heater into a continuing safe and normal operating condition. You must completely familiarize yourself with each model heater by reading and complying with the safety instructions, labels, Owner's Manual, etc., that is provided with each heater.
  - b. To be a authorized gas installation person, you must have sufficient training and experience to handle all aspects of installing, repairing and altering gas lines, including selecting and installing the proper equipment, and selecting proper pipe and tank size to be used. This must be done in accordance with all local, state and national codes as well as the manufacturer's requirements.
2. All installations and applications of L.B. White heaters must meet all relevant local, state, regional and national codes. Included are L.P. gas, natural gas, electrical, and safety codes. Your local fuel gas supplier, a local licensed electrician, the local fire department or similar government agencies, or your insurance agent can help you determine code requirements.
3. Do not move, handle, or service heater while in operation or connected to a power or fuel supply.
4. The heater is approved for outdoor mounting only. Therefore it will be exposed to inclement weather, such as rain. However, the heater may also be washed for cleaning if desired. This heater may only be washed on the external case assembly—see Cleaning Instructions. **Do not wash the interior of the heater. Use only compressed air, soft brush or dry cloth to clean the interior of the heater and it's components.**
5. For safety, this heater is equipped with a manual reset high-limit switch and an air flow switch. Never operate this heater with any safety device that has been bypassed. Do not operate this heater unless these features are fully functioning.
6. Do not operate the heater with its door open or panel removed.
7. Do not locate fuel gas containers or fuel supply hoses within 6,10 meters of the blower outlet of the heater
8. Do not block air intakes or discharge outlets of the heater. Doing so may cause improper combustion or damage to heater components leading to property damage or animal loss.
9. **Gas hose requirements:**
  - Where a hose assembly is used to install this appliance, only a hose certified in accordance with AS/NZS1869 shall be used.
  - The hose assembly shall be visually inspected on a daily basis.
  - If it is evident there is excessive abrasion or wear, if the hose is cut, or if the gas hose fittings are stripped or corroded, it must be replaced prior to the heater being put into operation
  - The hose assembly shall be protected from animals, building materials, and contact with hot surfaces during use.
10. Check for gas leaks and proper function upon heater installation, before building repopulation, or when relocating.
11. This heater should be inspected for proper operation by a qualified service person before building repopulation and at least annually.
12. Always turn off the gas supply to the appliance if the appliance is not going to be used in the heating of livestock.
13. The heater is wired for a three-wire electrical system. There is a hot lead, neutral lead, and a ground lead. The power cord may or may not incorporate a plug and the plug may or may not incorporate a pin for the ground wire. In any case, the heater must be properly connected into a grounded electrical supply using the ground lead in the power cord. Failure to use a properly grounded electrical supply can result in electrical shock, personal injury, or death.
14. Direct spark ignition heaters will make up to three trials for ignition. If ignition is not achieved after the third trial, the control system will "lock out" the gas control valve. If gas is smelled after system lock out has occurred, immediately close all fuel supply valves. Do not relight until you are sure that all gas that may have accumulated has cleared away. In any event, do not relight for at least 5 minutes.
15. When mounted outside, rigid pipe or copper tubing coupled directly to the heater may cause gas leaks during any vibration and therefore must not be used. Use only gas hose assemblies that are rated and approved for L.P. gas and natural gas.

# Installation Instructions

## GENERAL



### **WARNING**

#### **Fire or Explosion Hazard.**

#### **Can cause property damage, severe injury or death.**

1. Disconnect power supply before wiring to prevent electrical shock or equipment damage.
2. To avoid dangerous accumulation of fuel gas, turn off gas supply at the appliance service valve before starting installation, and perform gas leak test after completion of installation.
3. Do not force the gas control knob. Use only your hand to turn the gas control knob. Never use any tools. If the knob will not operate by hand, the control should be replaced by a qualified service technician. Force or attempted repair may result in fire or explosion.

- The heater must be installed in accordance with the Australian Gas Installation Standard AS/NZS 5601.
- The installer must test the operation of the appliance to ensure it functions correctly before Customer handover.
- If the appliance does not function correctly, the appliance must be removed from service immediately.
- An authorized and properly trained gas heater service person must be contacted to put the appliance back into proper working order.

1. Read all safety precautions and follow L. B. White recommendations when installing this heater. If during the installation or relocating of heater, you suspect that a part is damaged or defective, call a qualified service agency for repair or replacement.
2. Make sure the heater is properly positioned before use and is hung level. Observe and obey all minimum safe distances of the heater to the nearest combustible materials. Minimum safe distances are given on the heater nameplate and on page 4 of this manual.
3. **The heater is approved for outdoor installation only. Read all instructions that accompany the respective outdoor mounting kit for proper installation.**  
**Outdoor mounting kit part numbers:**  
**AD100 - 09811**  
**AD250: 24097**
4. Local, regional and national codes always apply to regulator installation. Typically, the appliance's gas regulator, with pressure relief valve, should be installed outside of the building. Any regulators inside the building must be properly vented to the outside.

5. Ensure that all packaging has been removed prior to installation. Any accessories, such as the sediment trap that ship within the heater, must also be removed and installed.

6. Make certain that a sediment trap is installed at the gas valve inlet to prevent foreign materials (pipe compound, pipe chips and scale) from entering the gas valve. Debris blown into the gas valve may cause that valve to malfunction resulting in a serious gas leak that could result in a possible fire or explosion causing loss of products, building or even life.

A properly installed sediment trap will keep foreign materials from entering the gas valve and protect the safe functioning of that important safety component.

7. For quick access in the event of an emergency, any heater connected to a piping system must have an accessible, approved manual shut off valve installed within 1.83 meters of the heater it serves.
8. Check all connections for gas leaks using approved gas leak detectors. Gas leak testing is performed as follows:



### **WARNING**

#### **Fire and Explosion Hazard**

- Do not use open flame (matches, torches, candles, etc.) in checking for gas leaks.
- Use only approved leak detectors.
- Failure to follow this warning can lead to fires or explosions.
- Fires or explosions can lead to property damage, personal injury or loss of life.

- Check all pipe connections, hose connections, fittings and adapters upstream of the gas control with approved gas leak detectors.
- In the event a gas leak is detected, check the components involved for cleanliness and proper application of pipe compound before further tightening.
- Tighten the gas connections as necessary to stop the leak.
- After all connections are checked and any leaks are stopped, turn on the main burner.
- Stand clear while the main burner ignites to prevent injury caused from hidden leaks that could cause flashback.
- With the main burner in operation, check all connections, hose connections, fittings and joints as well as the gas control valve inlet and outlet connections with approved gas leak detectors.

- 
- If a leak is detected, check the components involved for cleanliness in the thread areas and proper application of pipe compound before further tightening.
  - Tighten the gas connection as necessary to stop the leak.
  - If necessary, replace the parts or components involved if the leak cannot be stopped.
  - Ensure all gas leaks have been identified and repaired before proceeding.
9. A authorized gas installation and service agency must check for proper operating gas pressure upon installation of the heater.
  10. Light according to instructions on heater or within owner's manual.
  11. It is extremely important to use the proper size and type of gas supply line to assure proper functioning of the heater. Contact your fuel gas supplier or a qualified and authorized gas installation agency for proper line sizing and installation.
  12. Make sure the heater has the proper gas regulator for the application. A regulator must be connected to the gas supply so that gas pressure at the inlet to the gas valve is regulated within the range specified on the dataplate at all times. Contact your gas supplier, or the L.B. White Co., LLC if you have any questions.
  13. This heater can be configured for use with either L.P. gas vapor withdrawal or natural gas. Consult the heater's dataplate for the gas configuration of the heater. Do not use the heater in a propane liquid withdrawal system or application. If you are in doubt, contact the L.B. White Co., LLC
  14. Eventually, like all electrical/mechanical devices, the thermostat can fail. Thermostat failure may result in either an underheating or overheating condition which may damage critical products and/or cause animal injury or death. Critical products and/or animals should be protected by a separate back-up control system that limits high and low temperatures and also activates appropriate alarms.
  15. Take time to understand how to operate and maintain the heater by using this Owner's Manual. Make sure you know how to shut off the gas supply to the building and also to the individual heater. Contact your fuel gas supplier if you have any questions.
  16. Any defects found in performing any of the service or maintenance procedures must be eliminated and defective parts replaced immediately. The heater must be retested by authorized service personnel before placing the heater back into use.



## SEDIMENT TRAP ASSEMBLY

- Use pipe thread compound that is resistant to LP gas and natural gas in making all threaded connections.
- Ensure all threaded connections are tightened securely.
- See Fig.4 and the following instructions:
  - Assemble the sediment trap as follows:
    - 7.6 cm nipple to tee
    - Black iron cap to bottom of 7.6 cm nipple
    - Remove plastic cap from 6.3 cm nipple and thread this end into the black iron tee.
    - Connect to gas control valve inlet.
- Ensure the sediment trap is in the vertical position at the final tightening to the gas control valve. See image at right for gas control valve location.
- **Check all connections for gas leaks using approved gas leak detectors.**

**FIG. 4**

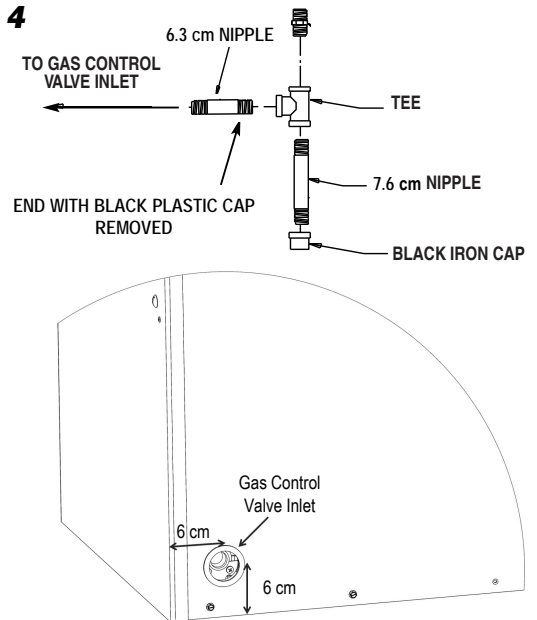

## ELECTRICAL CONNECTIONS

The heater shall be connected to an approved electrical supply by an authorized installation agency.

An electrical disconnect such as a circuit breaker should be installed to allow shut-down of the heater in the event of servicing, maintenance, or repair.

The heater's power cord is wrapped around the motor at the end of the heater opposite the gas inlet end of the heater.

Unwind the cord and route it through the case for connection to an approved electrical supply. See image to the right.

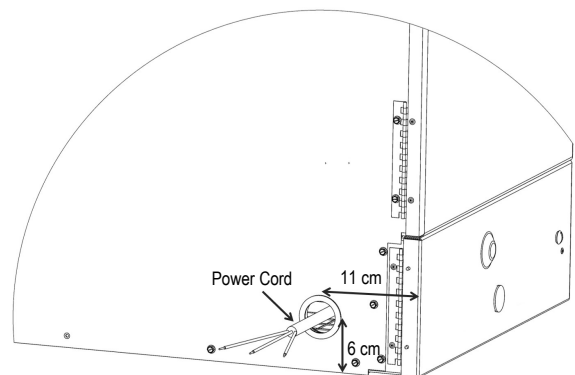

## THERMOSTAT INSTALLATION

**WARNING**  
**Electrical Shock Hazard**

- Disconnect the electrical supply before connecting the thermostat to the heater.
- Failure to follow this warning can result in electrical shock, leading to personal injury or death.

### To Connect the Direct Wired Thermostat Kit to the Control Box on the Heater:

1. The installation and wiring of a thermostat must be done by an authorized electrician.
2. The thermostat cordset must use a minimum of 18 gauge wire consisting of a hot lead, neutral lead, and a ground lead.

3. Disconnect the brown and white wires at the six wire terminal block on the ignition controller. Connect the thermostat wiring between these two wires. Refer to the heater's electrical connection diagram for thermostat connection.
4. The heater must be tested for proper operation after the thermostat has been connected.

## GAS HOSES AND REGULATORS

The heater's gas hose and regulator is not supplied by the L.B. White Co. The regulator and hose shall be supplied by an authorized gas installation agency.

The gas hose and regulator shall be of proper diameter and capacity to provide required gas supply pressure to the heater. See page 4 of this manual for required gas pressures.

## Start-Up Instructions

Follow steps 1 - 6 on initial start-up after heater installation by a qualified service person. For normal start-up, simply set the thermostat to a setting above room temperature.

1. Open all manual fuel supply valves and check for gas leaks using approved leak detectors.
2. The gas control valve has a manual shut-off feature incorporated into the valve assembly. Make sure the indicator on the control valve is positioned to On.

**FIG. 6**

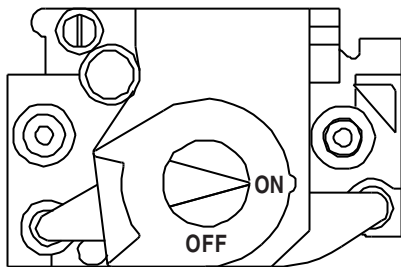

3. This heater includes a direct spark ignition (DSI) control module for purposes of controlling the timing of the ignition process of the heater as well as monitoring of the safety functions. The DSI module is located in the control box assembly. Refer to the troubleshooting guide within this Owner's Manual. Only qualified and properly-trained personnel shall service or repair the heater.
4. On a call for heat, the motor will start up and run for five (5) seconds prior to ignition trial. This pre-purge is a safety feature and a normal operational characteristic. After five (5) seconds the igniter will spark until burner flame is detected by the control module.

5. The ignition control will make three trials for ignition. If ignition is not proven after the third trial, the control will lock-out the heater. The ignition control must be reset to restart the heater. Push the reset switch until fan motor restarts, then release it. See Fig. 7.

**NOTE:** It is normal for air to be trapped in the gas hose on new installations. The heater may attempt more than one trial for ignition before the air is finally purged from the line and ignition takes place.

**FIG 7**

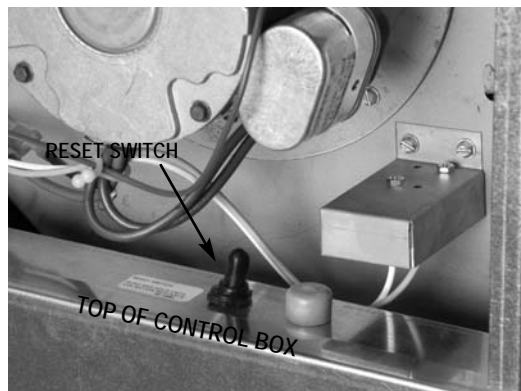

6. Do not exceed the input rating stated on the dataplate of the heater. Do not exceed the burner manifold pressure stated on page 4. Do not use an orifice size different than specified for the specific input rating of this heater, fuel type configuration and altitude.

## Shut-Down Instructions

If the heater is to be shut down for cleaning, maintenance or repair, follow steps 1 - 6. Otherwise, simply turn thermostat to "Off" or "No Heat" for standard shut down.

1. Close all manual fuel supply valves.
2. With the heater lit, allow heater to burn off excess fuel in gas supply hose.

3. Move the selector switch to the Off position.
4. Turn the indicator on the gas control to Off.
5. Turn thermostat to Off or No Heat position.
6. Disconnect the heater from the electrical supply.

## Cleaning Instructions



### **WARNING** Fire, Burn, and Explosion Hazard

- This heater contains electrical and mechanical components in the gas management, safety and airflow systems.
- Such components may become inoperative or fail due to dust, dirt, wear, aging, or the corrosive atmosphere of an animal confinement building.
- Periodic cleaning and inspection as well as proper maintenance are essential to avoid serious injury or property damage.
- The appliance area shall be kept clear and free from combustible materials, gasoline, and other flammable vapors and liquids.

1. Before cleaning, shut off all gas supply valves and disconnect electrical supply.
2. The heater should have dirt or dust removed periodically:
  - a. After each flock or between building re-population, give the heater a general cleaning using compressed air or a soft brush on its interior and exterior. At this time, dust off the motor case to prevent the motor from over-heating and shutting the heater down.
  - b. At least once a year, give the heater a thorough cleaning. At this time, remove the fan and motor assembly and brush or blow off the fan wheel, giving attention to the individual fan blades. Make sure the burner air inlet venturi ports and the “throat” of the casting are free of dust accumulation and the area between the heat chamber top and inside case is also free of dust. Additionally, the igniter and flame sensor assembly should be removed and cleaned in accordance to the service instructions within this Owner’s Manual.
  - c. If washing with water, observe and obey the Warning within these Cleaning Instructions. This same Warning is also supplied on the heater.



### **WARNING**

This heater may be washed only on the external case assembly provided:

- A. The heater is disconnected from the electrical supply.
- B. All access panels are securely closed.
- C. Water spray nozzle shall not discharge within 1.83 m of the heater.
- D. The water pressure does not exceed 3.1 BAR for 10 seconds on each side of heater.
- E. The heater is not reconnected to electrical supply for a minimum of 1 hour or until the heater is thoroughly dry.

Improper cleaning of the heater can cause severe personal injury or property damage due to water and/or cleaning solution:

1. In electrical components, connections and wires causing electrical shock or component failure.
2. On gas control components causing corrosion which can result in gas leaks and fire or explosion from the leak.

Clean internal components of the heater with a soft, dry brush or cloth, or compressed air.

## Maintenance Instructions

1. Have your authorized gas supplier check all gas piping annually for leaks or restrictions in the gas lines. Also at this time have your gas supplier perform the following scope of service program recommended by the L.B. White Company.
  - a. Review all heater markings prior to use. Markings constitute information relating to warnings, start-up, shut-down instructions, etc. Any damaged markings should be replaced immediately. Contact the L.B. White Company for replacement.
  - b. Check the regulators delivery pressures to the appliance to make sure the regulator is reliable. Regulator vents should be inspected for blockage. A blocked vent will cause excess pressure at the appliance.
2. Annually inspect all electrical connection and wires within the heater and its control box. Replace any wires or terminals that are corroded, loose, nicked, burnt, or cut.
3. Annually check all gas hoses for nicks, cuts, corrosion, or stripped fittings. If defects are found, replace the complete gas hose assembly.

# Service Instructions

## GENERAL

**WARNING**  
**Burn Hazard**

- Heater surfaces are hot for a period of time after the heater has been shut down.
- Allow the heater to cool before performing service, maintenance, or cleaning.
- Failure to follow this warning will result in burns causing injury.

**WARNING**  
**Fire and Explosion Hazard**

- Do not disassemble or attempt to repair any heater components or gas train components.
- All component parts must be replaced if defects are found.
- Failure to follow this warning will result in fire or explosions, causing property damage, injury, or death.

1. Close the fuel supply valve to the heater and disconnect the electrical supply before servicing unless necessary for your service procedure.
2. Clean the heater's orifice with compressed air or a soft, dry rag. Do not use files, drills, broaches, etc. to clean the orifice hole. Doing so will enlarge the hole, causing combustion or ignition problems. Replace the orifice if it cannot be cleaned properly.

3. The high limit switch, fuse, and thermostat can be tested by disconnecting the leads at the component, and jumpering the leads together:
  - Reconnect the electrical supply and open fuel supply valves.
  - If the heater lights, the component is defective and must be replaced.
  - Do not leave the jumper on or operate the heater if the part is defective. Replace the part immediately. -- An alternate method for checking the components is to perform a continuity check..
4. The air proving switch must not be jumpered. If jumpered, the ignition control will not allow heater operation. Test the air proving switch for continuity. If defective, replace the switch
5. Open the respective case panel for access to burner or fan related components. Open the control box for access to the ignition controller, relay, transformer, fuse holder, and reset switch.
6. Disconnect the appropriate electrical leads when replacing components.
7. For reassembly, reverse the respective service procedure. Ensure gas connections are tightened securely.
8. After servicing, start the heater to ensure proper operation and check for gas leaks.

## MOTOR AND FAN WHEEL ASSEMBLY

1. Remove the screws securing the motor mounting plate to the fan housing. See Fig.10.
2. Pull the fan and motor assembly from the housing.
3. Loosen the square head set screw(s) on the fan wheel with a wrench.
4. Pull the fan wheel from the motor shaft. Use a wheel puller if necessary.
5. Remove the four (4) nuts securing the motor to the mounting plate.

NOTES: a. Fan wheel to motor mount plate spacing must be adjusted to 6.4 mm clearance before tightening the fan wheel to the motor shaft.

- b. Make sure that set screw(s) of the fan are on the flats of motor shaft when tightening.

**FIG. 10**

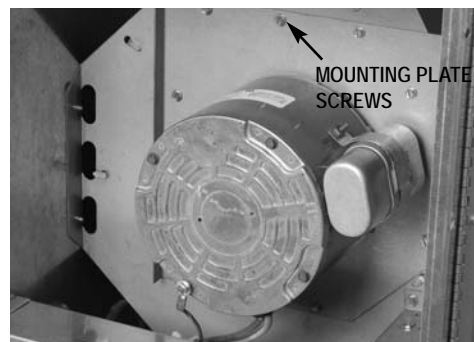

**FIG. 11**

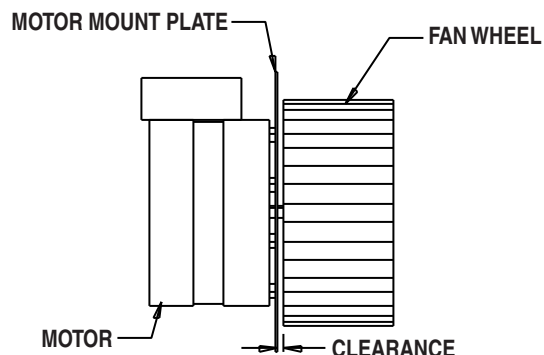

## AIR PROVING SWITCH WITH PADDLE

The air proving switch must work properly to allow an ignition cycle. If the air proving switch contacts do not close on a call for heat after the fan motor starts, neither spark nor ignition will occur.

1. Remove the two (2) sheet metal screws holding the switch with bracket to blower housing. See Fig.12.
2. Remove the assembly by turning the switch assembly so the paddle on the switch arm can be pulled through the oblong hole on side of fan housing.
3. Disconnect the leads from the air proving switch.

**FIG. 12**



**WARNING**  
**Fire Hazard**

- Do not operate the heater with the high limit switch bypassed.
- Operating the heater a bypass high limit switch may lead to overheating, possibly resulting in a fire, with subsequent damage to the heater, building damage, or loss of livestock.

This heater uses a high limit heat switch for the purpose of over heat protection. The high limit switch is located on the heat chamber, see Fig. 13, and is connected between the fuse and the gas control valve.

The switch has normally closed contacts. If an overheat condition occurs, the switch contacts will open, thereby opening the circuit to the gas control valve.

The high limit switch should be tested a minimum of once per year when the heater is given a thorough cleaning.

**FIG. 13**



## MANUAL RESET HIGH LIMIT SWITCH

1. Holding the switch by one of its mounting legs, apply a small flame only to the sensing portion on the back of the switch. **Be careful not to melt the plastic housing of the switch when conducting this test.**
2. Within a minute, you should hear a pop coming from the switch, which indicates the contacts of the switch have opened. Check for lack of electrical continuity across the switch terminals to verify contacts have opened.
3. Allow the switch cool down for about a minute before firmly pressing the reset button on the switch.
4. Check for electrical continuity across the switch terminals to make sure the contacts have closed.
5. Reinstall the switch back into the heater. Reconnect the heater to its electrical supply. Start the heater and check for proper operation.

**FIG. 14**

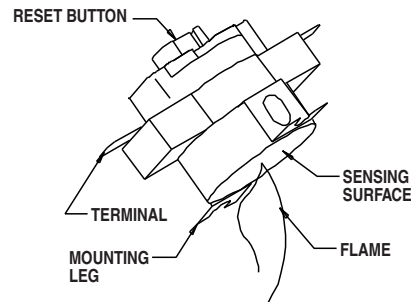

## IGNITION CONTROLLER

The controller will attempt three trials for ignition if ignition of the fuel gas does not occur. Each trial takes approximately 15 seconds. If ignition is not achieved, the ignition control shuts the heater down.

- Ignition spark is discontinued
- Fan motor stops
- **The ignition control must be reset to restart the heater.**

If replacing, carefully remove the wiring harnesses and ignition cable from the controller.

**The ignition controller does not have any serviceable components. If the controller is defective, it must be replaced. Do not attempt to repair.**

**FIG. 15**

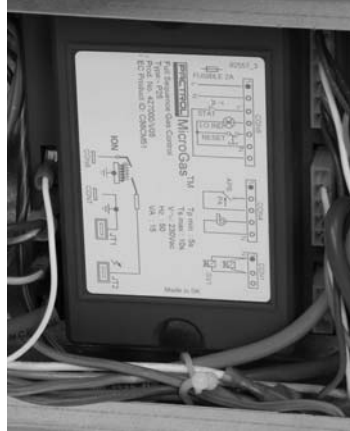

## RELAY

Refer to Fig. 16 ( shown w/o wires connected for clarity) and following table for connection of wiring and voltage checks.

The relay has numbers adjacent to the male 6.4 mm male terminals for reference.

Terminal	Function
2	Incoming power to ignition controller
4	Power to fan motor
6	Neutral for fan motor
8	Neutral for ignition controller
0	220/240 VAC input for relay coil closure (sends 220/240 VAC from terminal 2 to terminal 4 to start the motor)
1	Neutral for relay

If the relay is receiving 220/240 VAC but voltage is not supplied to the fan motor, the relay is defective.

**FIG. 16**

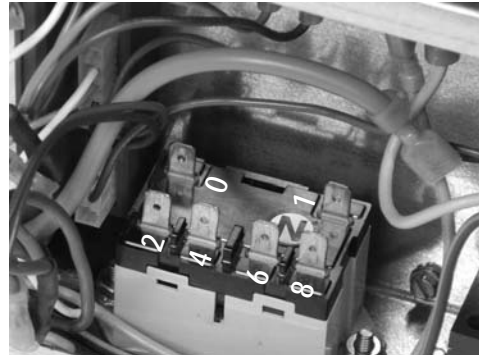

## TRANSFORMER

The transformer reduces 220/240VAC to 24 VAC for operation of the gas control valve. If 24 VAC is absent from the transformer, the gas control will not open and ignition will not occur.

See Fig.17 for location of the transformer and output terminal reference.

**FIG. 17**

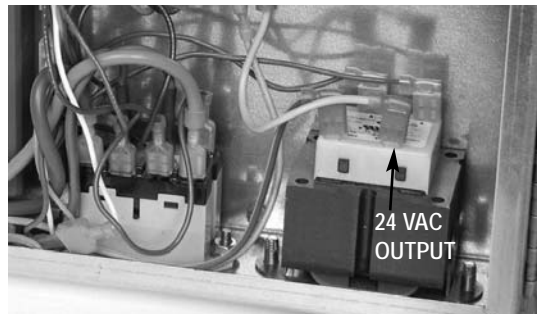

## RESET SWITCH

The reset switch is located on the top of the control box at the fan motor end of the heater. See Fig. 18.

Turn the rubber boot counterclockwise to remove the boot from the switch.

Check for electrical continuity across the component to determine if it is defective.

**FIG. 18**

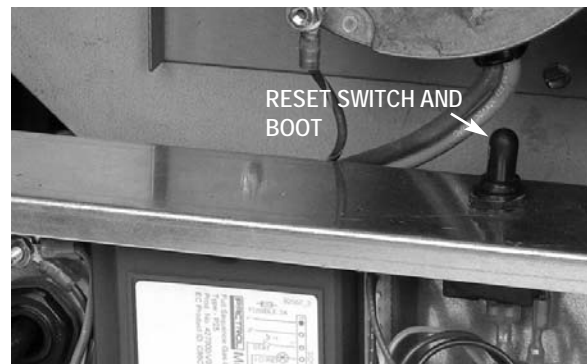



## IGNITER AND FLAME SENSOR

■ The igniter/sensor assembly may require cleaning due to accumulations of dust and dirt over a period of time, affecting its ability to ignite fuel gas and sense burner flame. Cleaning will require igniter/sensor removal.

- If spark appears to be weak, rub the igniter electrode with emery cloth or steel wool to remove any buildup.
- If the spark appears strong but the heater cycles off, rub the sensor rod with emery cloth or steel wool to remove any build-up.

■ Ensure the igniter gap is 4.0 mm and the igniter tip is positioned over the burner port according to the illustration below. See Fig. 19.

**FIG. 19**

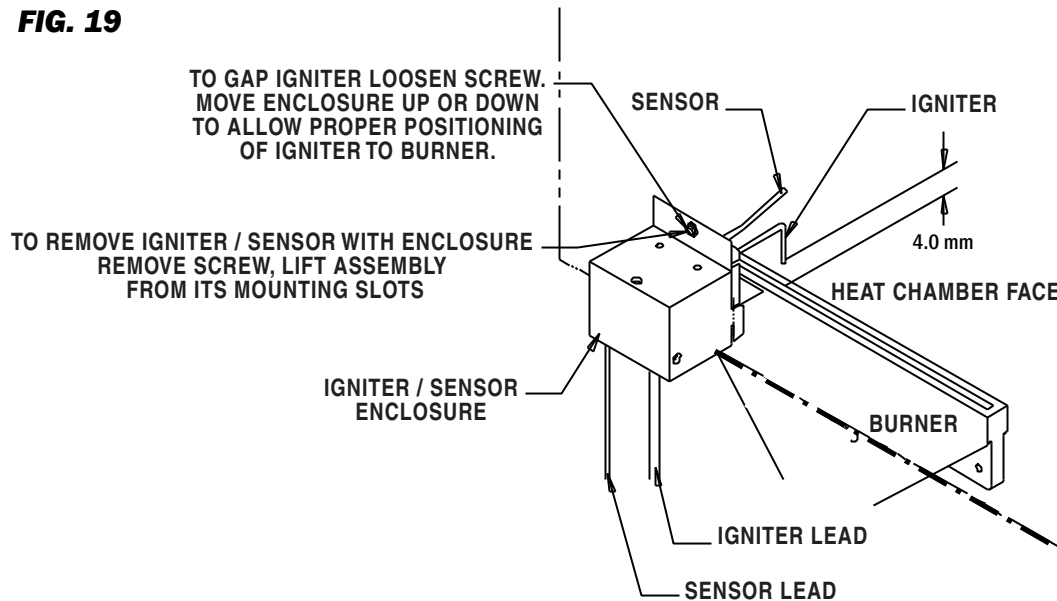

## GAS CONTROL VALVE AND BURNER ORIFICE

1. Remove the following in the order given:
  - Gas hose and sediment trap from the inlet of gas the control valve.
  - Two screws at the inlet of the gas control valve securing the valve to the case. See Fig. 20.
  - Bolt with washer securing the manifold to the burner and base. See Fig.21.
2. Lift and pivot the gas valve with manifold as needed to so burner orifice clears the venturis of the burner. See Fig.22.
3. Replace components as needed.

**FIG. 21**

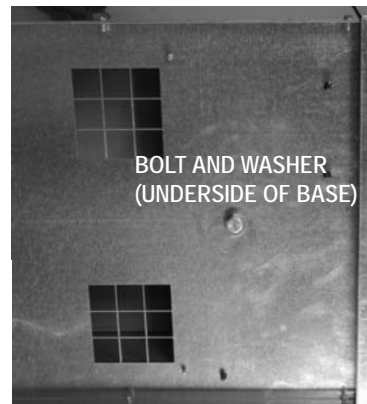

**FIG. 20**



**FIG. 22**

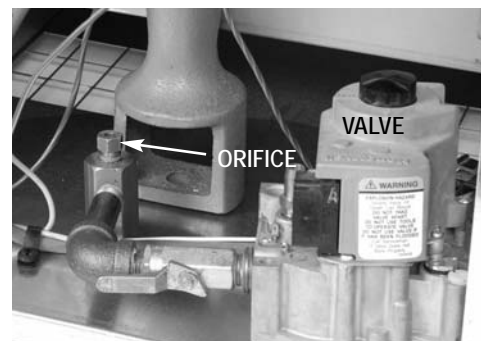

## GAS PRESSURE CHECKS



### WARNING

#### Fire and Explosion Hazard

- Do not disassemble the gas control valve or attempt to replace any components on the gas control valve.
- Replace the gas control valve if any physical damage occurs to the control valve.
- Failure to follow this warning will result in fire or explosions, leading to injury or death to humans and livestock, and building damage.

- The following explains a typical procedure to be followed in checking gas pressures.
- The gas pressures will vary depending upon country, gas category and fuel type.
- Consult the dataplate on the heater or page 4 in this manual for specific pressures to be used in conjunction with this procedure.
- Gas pressure measured at the inlet to the gas valve is Inlet Pressure and gas pressure measured at the outlet of the gas valve is Burner Manifold Pressure.

#### A. Preparation

1. Obtain two pressure gauges capable of reading up to 8.7 kPa.
2. Disconnect the heater from the electrical supply and close the fuel supply valve to the heater inlet.
3. Open the burner access panel.
4. Brush or blow off any dust and dirt on or in the vicinity of the gas control valve.

#### B. Gauge Installation

1. Locate the inlet and outlet pressure taps, see Fig.23. Turn screws internal to the pressure taps at least one full turn counterclockwise.
2. Securely connect a pressure gauge to each pressure tap.
3. Open the fuel supply valves to the heater and reconnect the heater electrical supply.
4. Start the heater.

#### C. Reading Pressures

1. With the heater operating, the pressure gauges should read the pressures specified on page 4.
2. Do the readings at the inlet and outlet pressure gauges agree with that specified on page 4? If so, then no further checking or adjustment is required. Proceed to Section D.
3. If the inlet pressures do not agree with that specified on page 4, then the building system regulator controlling gas pressure to the heaters requires adjustment.

4. If the inlet pressures are correct and the burner manifold pressure does not agree with that specified on page 4, then the gas control valve's internal pressure regulator requires adjustment. See Fig.24 for regulator location.

#### D. Completion

1. Once inlet and burner manifold pressures have been confirmed and/or properly set, close the fuel supply valve to the heater and allow the heater to burn off any gas remaining in the gas supply line.
2. Disconnect the heater from its electrical supply.
3. Remove the gauges and connecting hoses.
4. Tighten the pressure tap screws by turning clockwise. Check for gas leaks to insure the tap screws have seated properly.

**FIG. 23**

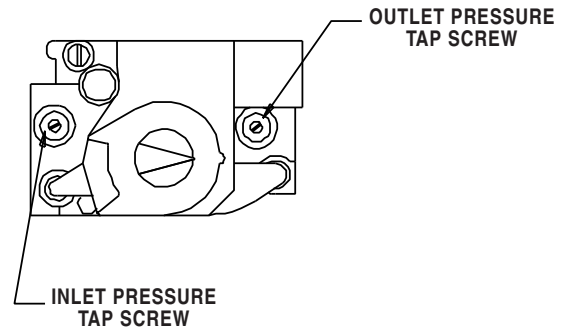

**FIG. 24**

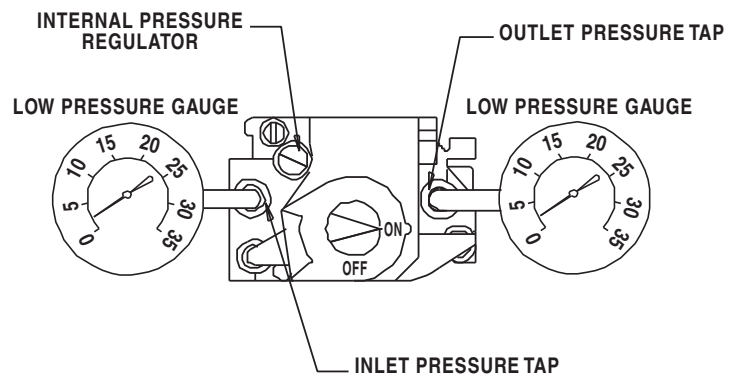



# Troubleshooting Guide

## READ THIS ENTIRE SECTION BEFORE BEGINNING TO TROUBLESHOOT PROBLEMS.



### WARNING

#### Electrical Shock and Burn Hazard

- Troubleshooting this system may require operating the unit with line voltage present and gas on. Use extreme caution when working on the heater.
- Failure to follow this warning may result in property damage, personal injury, or death.

The following troubleshooting flow charts provide systematic procedures for isolating equipment problems.

### DO NOT SERVICE THESE HEATERS UNLESS YOU ARE AN AUTHORIZED GAS HEATER SERVICE PERSON..

#### TEST EQUIPMENT REQUIRED

The following pieces of test equipment will be required to troubleshoot this system.

- **Digital Multimeter** - for measuring AC and DC voltage and resistance.
- **Low Pressure Gauge** - for checking inlet and outlet pressures of the gas control valve against dataplate rating.

#### INITIAL PREPARATION

- Visually inspect equipment for apparent damage.
- Check all wiring for loose connections and worn insulation.

Refer to the system operation sequence in this section to understand how the heater operates during a call for heat.

If the heater is not operational, push and release the reset switch to restart the heater. Observe heater operation. Identify the problem and refer to the appropriate troubleshooting flow charts for problem solving. Perform all troubleshooting steps identified by the flow charts.

<u>Problems</u>	<u>Page</u>
Fan motor does not run, heater does not light. . . . .	18
Fan motor runs, igniter does not spark. . . . .	19
Fan motor runs, igniter sparks, but heater does not light . . . . .	20
Heater lights, but does not stay lit . . . . .	21

Components should be replaced only after each step within the flow chart has been completed and replacement is suggested in the flow chart. Refer to the Servicing sections as necessary to obtain information on disassembly and replacement procedures of the component. Verify proper heater operation after servicing.

#### DIRECT IGNITION OPERATION SEQUENCE:

- Line voltage is supplied to motor relay, ignition control and thermostat.
- A call for heat occurs from the thermostat.
- Thermostat contacts close.
- Ignition control performs self safety check
  - Internal components are tested
  - Air proving circuit is checked
- Ignition control sends line voltage to motor relay.
  - Relay contacts close
  - Relay sends power to fan motor
  - Fan motor starts
- Ignition control sends line voltage to air proving switch.
  - Air proving switch contacts close on an increase in air pressure.
- Ignition control begins ignition trial sequence.
- Ignition control sends line voltage to transformer.
- Transformer reduces line voltage to 24 volts.
  - 24 volts is sent to fuse.
  - Fuse sends 24 volts to high limit switches.
  - High limits send 24 volts to gas control valve.
  - Gas control valve opens.
- Ignition control sends high voltage to igniter electrode.
  - Igniter sparks.
  - Ignition occurs.
- Igniter continues to spark until flame proving occurs.
  - Ignition spark is shut off.
  - Gas control valve stays open.
- Room warms to desired temperature.
  - Thermostat is satisfied, thermostat contacts open.
  - Heater shuts down.
- Process begins again on a call for heat.

#### IGNITION FAILURE SEQUENCE

- There are three trials for ignition. Each trial for ignition takes approximately 15 seconds
- If ignition is not maintained, the ignition control shuts the heater down.
  - Gas valve closes
  - Ignition spark is discontinued
  - Fan motor stops
- **The ignition control must be reset to restart the heater.**
  - **Push and hold the reset switch until fan motor restarts.**

**Problem**  
**Fan Motor Does Not Run, Heater Does Not Light.**

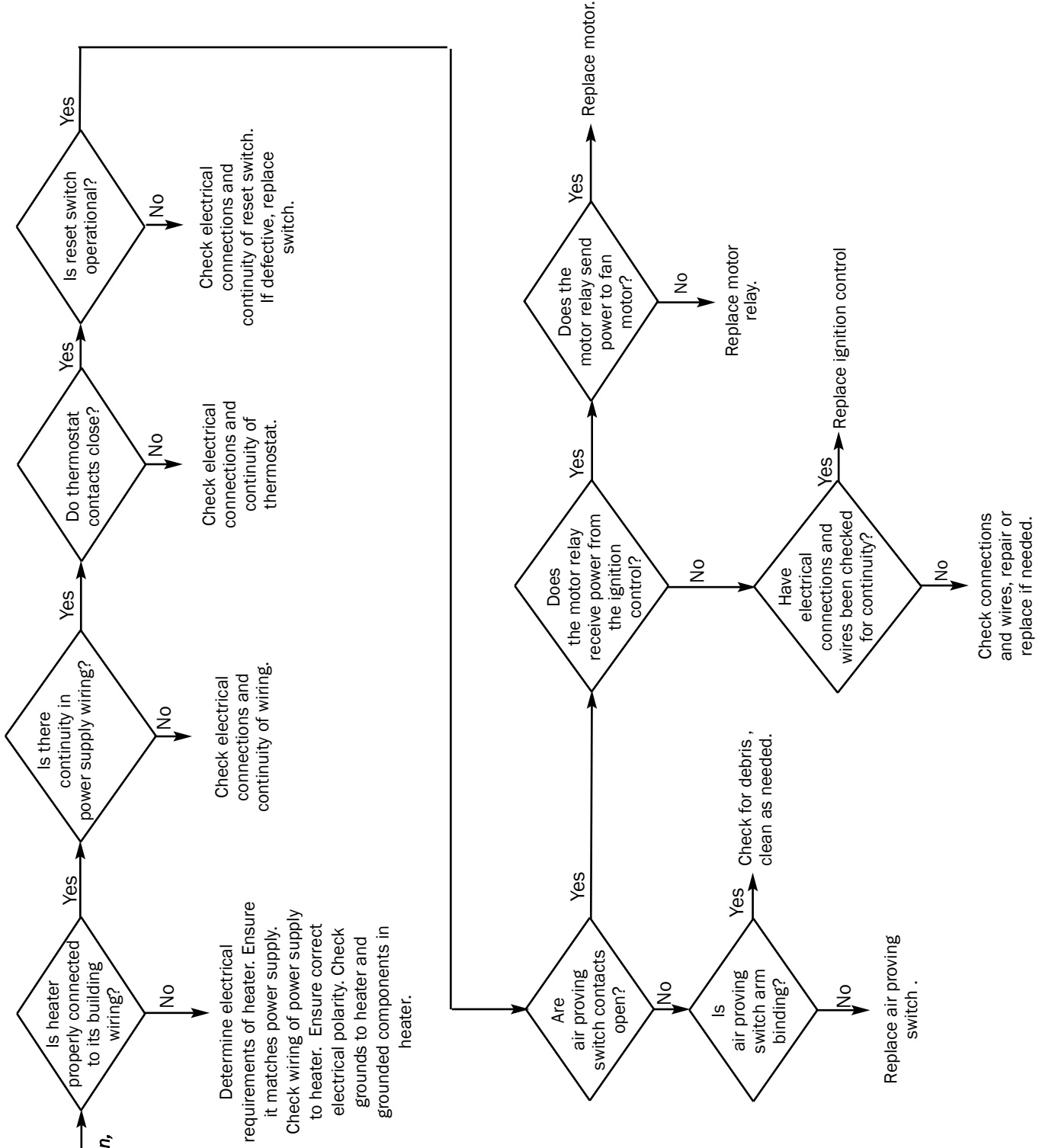

**Problem**  
**Fan Motor**  
**Runs Igniter**  
**Does Not**  
**Spark.**

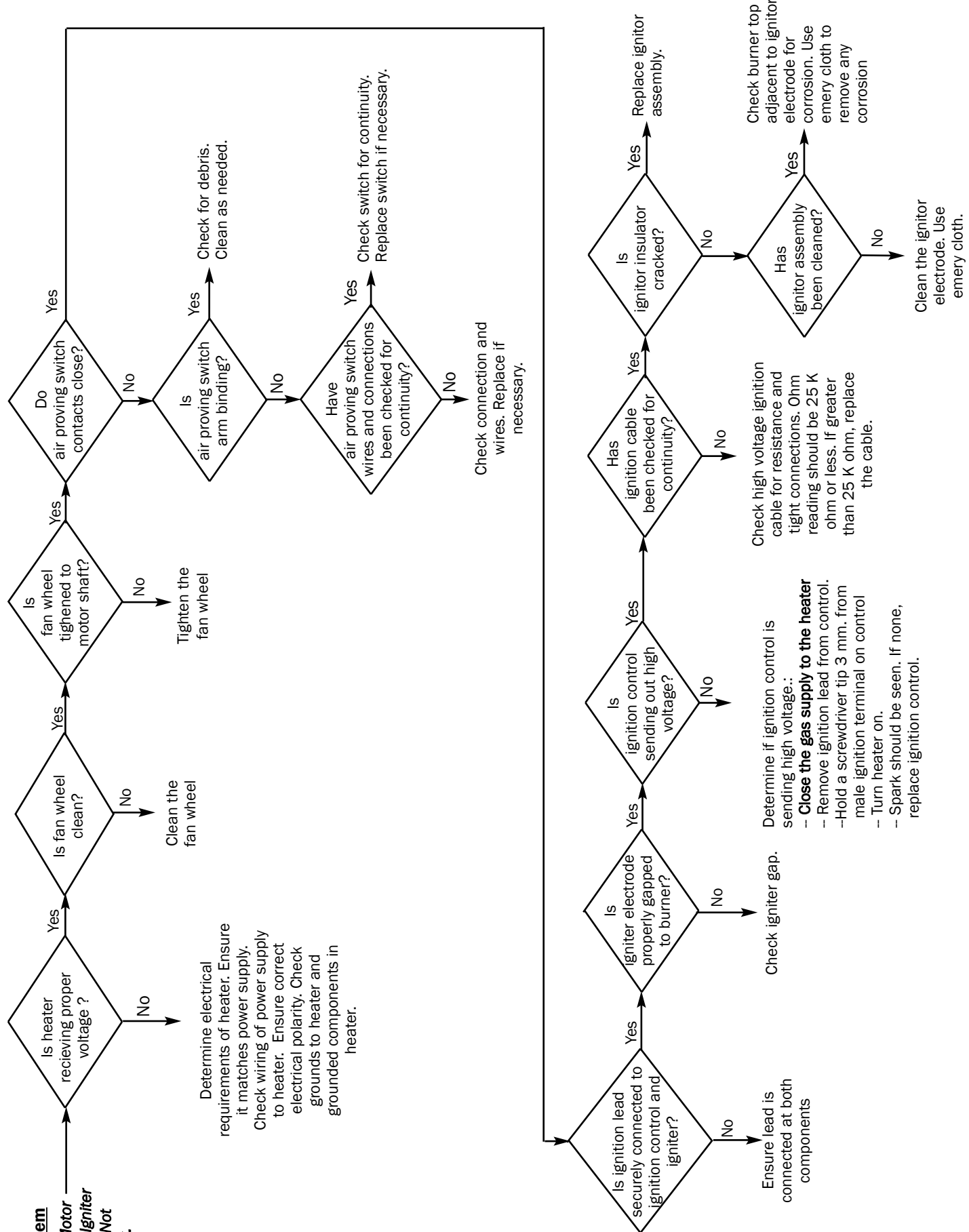

**Problem**

**Fan Motor  
Runs, Igniter  
Sparks, Heater  
Does not  
Light.**

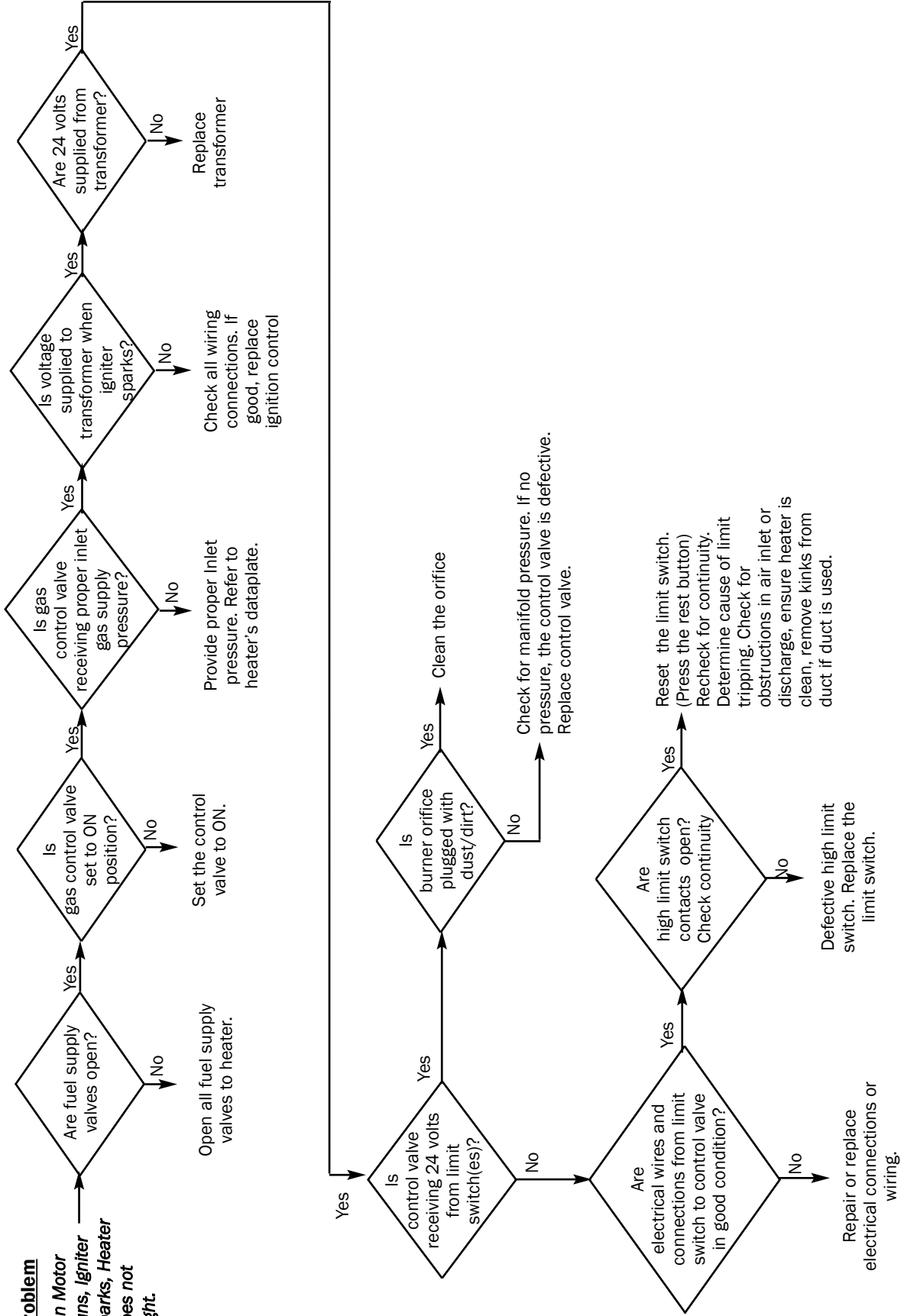

**Problem**

**Heater Lights,  
But Doesn't  
Stay Lit.**

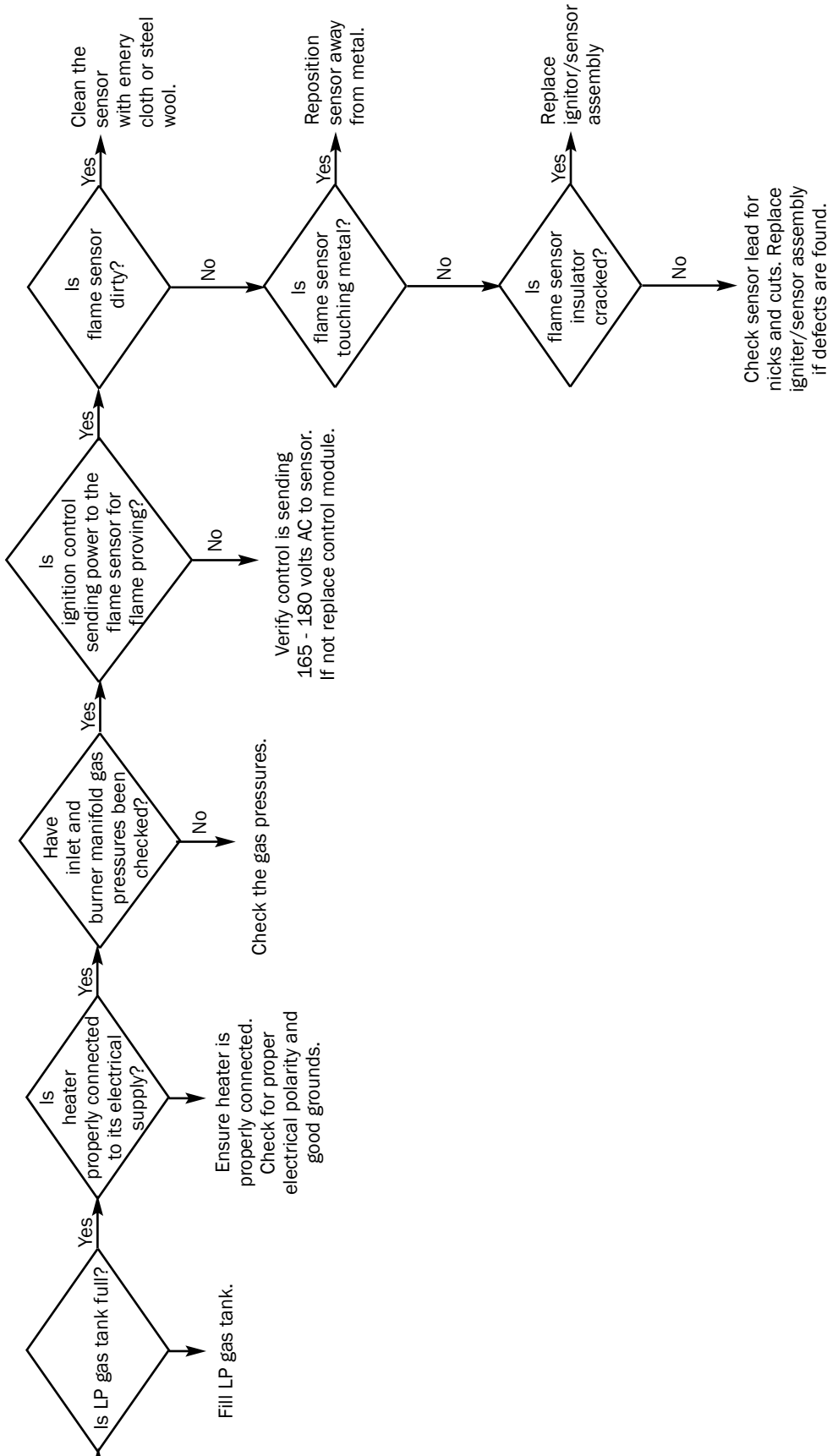

**NOTES:**

- (1) With any electrical problem, all wiring should be checked for good connections and proper voltage.
- (2) The ignition control module sends and receives voltages throughout the entire operation sequence. The ignition control module terminals should also be checked for delivering proper voltages in addition to the individual components to make sure the board itself is working properly.
- (3) The high limit switch will activate for a number of reasons. Common problems associated with this are high gas pressure, low voltage, loose or dirty fans, restrictions/blockages at air inlets or outlets, or excessive dust and dirt accumulations in the heater.

# Electrical Connection and Ladder Diagram

CAUTION: REFER TO HEATERS ELECTRICAL CONNECTION DIAGRAM WHEN SERVICING THE HEATERS ELECTRICAL COMPONENTS TO AVOID WIRING ERRORS AND EQUIPMENT MALFUNCTION. CHECK FOR PROPER OPERATION AFTER SERVICING.

WARNING: THIS HEATER MAY START AT ANY TIME

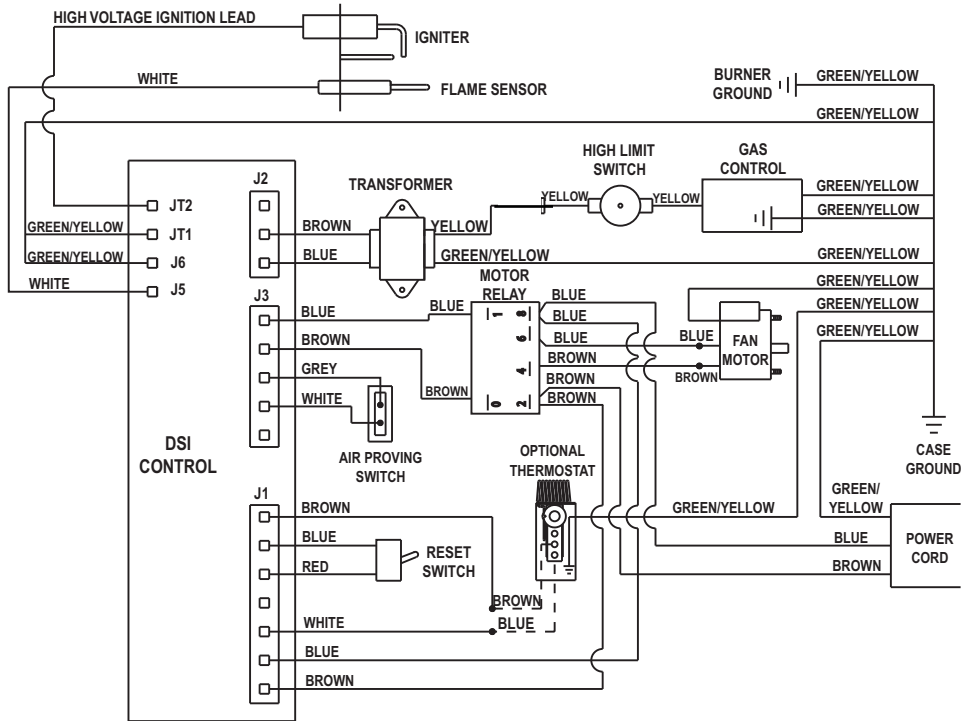

ELECTRICAL CONNECTION DIAGRAM

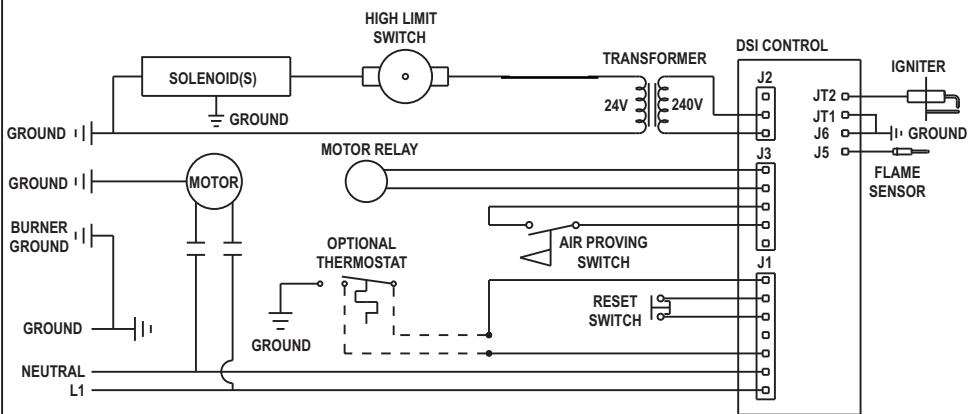

ELECTRICAL LADDER DIAGRAM

IF ANY OF THE ORIGINAL WIRE AS SUPPLIED WITH THE HEATER MUST BE REPLACED, IT MUST BE REPLACED WITH WIRING MATERIAL HAVING A TEMPERATURE RATING OF AT LEAST 302°F (150°C)

---

# Heater Component Function

## **Air Proving Switch**

Safety device used to insure that the proper air flow is being achieved before the gas valve is opened.

## **Burner**

Cast iron component used to mix air and gas and provide an area at which the fuel may ignite.

## **Burner Orifice**

Brass metering device used to supply gas to burner at a specific rate.

## **Direct Spark Ignition Control Module**

Electronic printed circuit board which sends and receives voltages to various controls in an automatic ignition system. An important safety feature of the control board is that it will shut down the entire heater, thereby stopping the flow of fuel gas if burner flame goes out.

## **Fan Housing**

Chamber used for delivering air for efficient air movement.

## **Fan Wheel**

Component used in conjunction with the motor and fan housing to pull the hot air from heater and blow it into room for heating (also known as a squirrel cage).

## **Gas Control Valve**

Electrical device consisting of a low pressure regulator and electrical solenoids used for the control of gas flow to the burner assembly. A feature of the control valve is a built-in gas shut off which may be used to isolate the heater from its gas supply when servicing.

## **Gas Hose**

Flexible connector used to deliver gas from supply line in building to heater.

## **Heat Chamber**

Metal fire box that provides an area where burner flame mixes with combustion air thereby providing heat.

## **High Limit Switch**

Safety device wired into the control system which is used to break an electrical circuit to the gas control valve in event of overheat situation.

## **Igniter**

Ignition device used on automatic direct spark ignition control systems. Ignites gas by spark.

## **Motor**

Electric device used to drive a fan to pull preheated air through the heater and to circulate heat within a certain area. Converts electrical energy into mechanical energy.

## **Regulator**

Mechanical device used in L.P. and natural gas distribution systems to reduce a higher inlet pressure to a preset lower pressure. The regulator is responsible to supply a steady outlet pressure to the heater(s) despite changes in inlet pressure, heater demand and weather conditions.

## **Relay**

Electrical component used to deliver voltage from the ignition control to the fan motor during initial start-up and operation.

## **Reset Switch**

Electrical component used for resetting the ignition control module to restart the heater if a problem occurs.

## **Thermostat**

Electrical device used as an automatic on/off switch which will respond to changes in temperature in a certain area. Can be wired so contacts in the thermostat open or close on temperature increase or decrease.

## **Transformer**

Electrical control used to accept line power supply primary voltage and reduce it to lower secondary voltage to operate certain control systems.

# Parts Identification

## PARTS SCHEMATIC

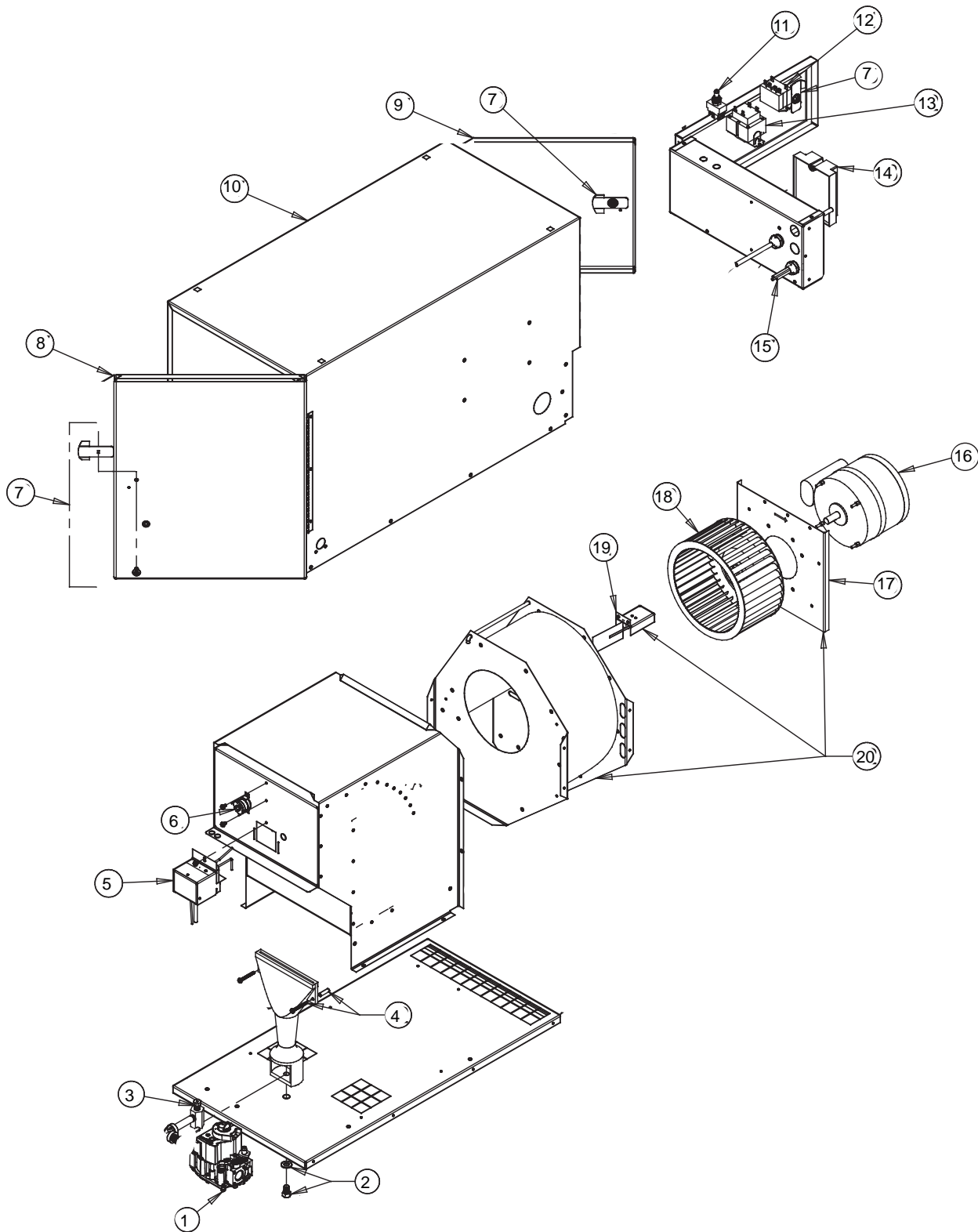



---

**PARTS LIST**

<b>Item</b>	<b>Description</b>	<b>Part Number</b>
1	Gas control valve (Propane gas)	22420
	(Natural gas)	22421
2	Bolt and washer	25866
3	Burner orifice (Propane gas)	572410
	(Natural gas)	573012
4	Burner mounting hardware	570211
5	Igniter and sensor assembly	525517
6	Switch, High Limit	573099
7	Latch assembly	20959
8	Door, right	573129
9	Door, left	573603
10	Case assembly with doors and latches	573605
11	Reset switch with boot	571907
12	Relay	571916
13	Transformer	571900
14	Ignition control	525516
15	Wiring kit with harness	573018
16	Motor	571929
17	Motor mount (Galvanized)	570383
18	Fan wheel	571928
19	Air proving switch with mounting hardware	573038
20	Fan housing assembly, with motor mount, and air proving switch	573039

# Parts Identification

## PARTS SCHEMATIC

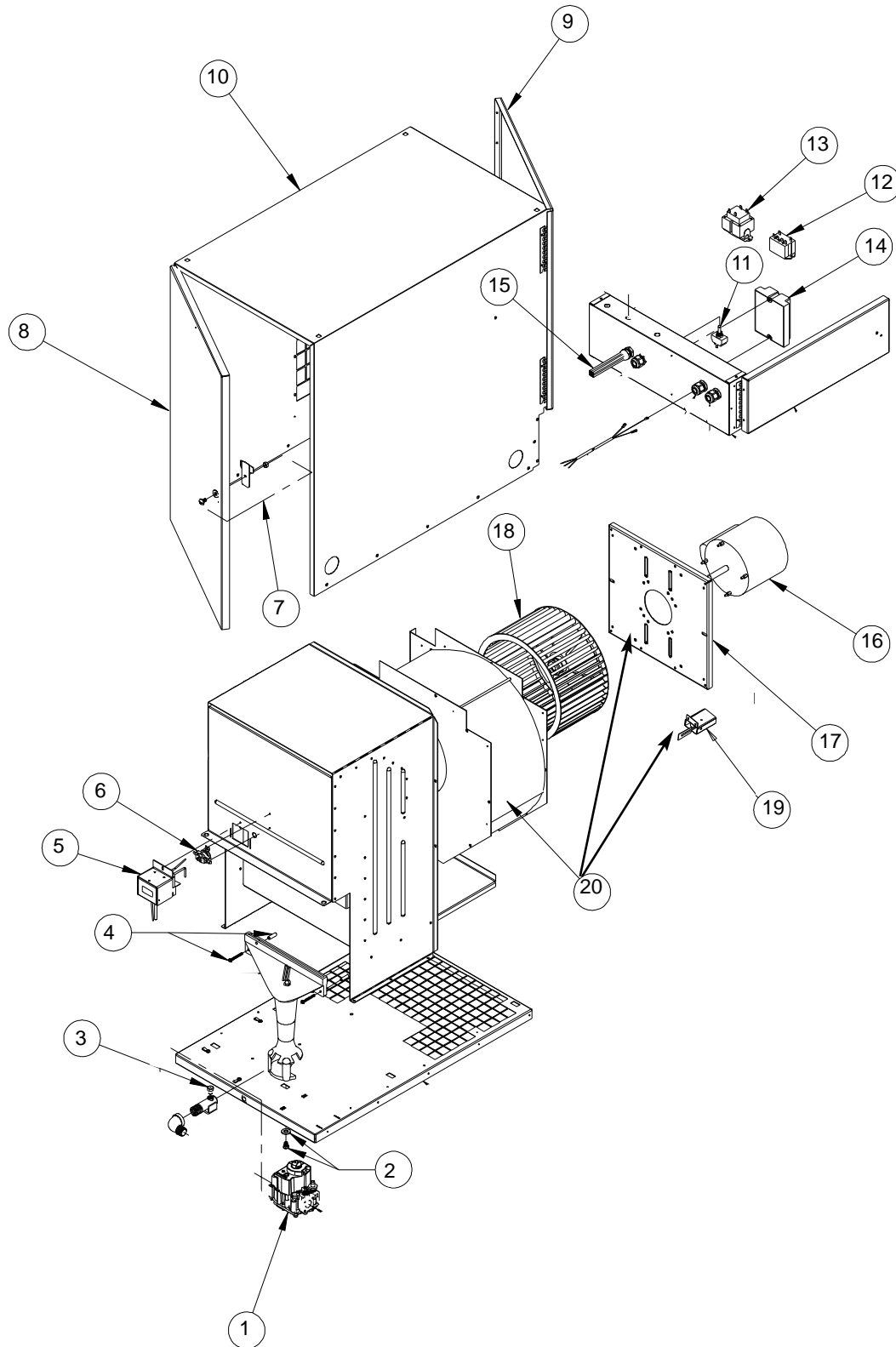

---

**PARTS LIST**

<b>Item</b>	<b>Description</b>	<b>Part Number</b>
1	Gas control valve (Propane gas)	22420
	(Natural gas)	22421
2	Bolt and washer	25866
3	Burner orifice (Propane gas)	570053
	(Natural gas)	571940
4	Burner mounting hardware	570211
5	Igniter and sensor assembly	525517
6	Switch, High Limit	505566
7	Latch assembly	20959
8	Door, right	525523
9	Door, left	573604
10	Case assembly with doors and latches	573608
11	Reset switch with boot	571907
12	Relay	571916
13	Transformer	571900
14	Ignition control	525516
15	Wiring kit with harness	572063
16	Motor	571902
17	Motor mount	570251
18	Fan wheel	570481
19	Air proving switch with mounting hardware	24157
20	Fan housing assembly, with motor mount, and air proving switch	24167

---

## **Warranty Policy**

### **EQUIPMENT**

---

L.B. White Co., LLC warrants that the component parts of its equipment are free from defects in material and workmanship, when properly installed, operated, and maintained in accordance with the Installation and Maintenance Instructions, safety guides and labels contained with each unit. If, **within 12 months from the date of purchase by the end user**, any component is found to be defective, L.B. White Co., LLC will at its option, repair or replace the defective part or equipment, with a new part or equipment, F.O.B., Onalaska, Wisconsin.

A warranty card on file at L.B. White will automatically qualify a unit and its component parts for warranty consideration. If a warranty card is not on file, a copy of the bill of sale will be required to establish warranty qualification. If neither is available, the warranty period will be 12 months from date of shipment from L B. White.

### **PARTS**

---

L.B. White Co., LLC warrants that replacement parts purchased from the company and used on the appropriate L. B. White equipment are free from defects both in material and workmanship for **12 months from the date of purchase by the end user**. Warranty is automatic if a component is found defective within 12 months of the date code marked on the part. If the defect occurs more than 12 months later than the date code but within 12 months from the date of purchase by the end user, a copy of a bill of sale will be required to establish warranty qualification.

duration to the duration of the applicable warranty stated above. The remedies set forth above are the sole and exclusive remedies available hereunder. L.B. White will not be liable for any incidental or consequential damages directly or indirectly related to the sale, handling or use of the equipment, and in any event L.B. White's liability in connection with the equipment, including for claims based on negligence or strict liability, is limited to the purchase price.

The warranty set forth above is the exclusive warranty provided by L.B. White, and all other warranties, including any implied warranties or merchantability or fitness for a particular purpose, are expressly disclaimed. In the event any implied warranty is not hereby effectively disclaimed due to operation of law, such implied warranty is limited in

Some regions do not allow limitations on how long an implied warranty lasts, so the above limitation may not apply to you. Some regions do not allow the exclusion or limitation of incidental or consequential damages, so the above limitation or exclusion may not apply to you. This warranty gives you specific legal rights, and you may also have other rights which vary from region to region.

---

## **Replacement Parts and Service**

Contact your local L.B. White dealer for replacement parts and service or call the L.B. White Company, LLC at (608) 783-5691 for assistance. Be sure that you have your heater model number and configuration number when calling.